

KTM

ERSATZTEILKATALOG 198 SPARE PARTS MANUAL 98



FAHRGESTELL

ART. NR. 3.204.57
5.98

KTM 640 LC4-E/mil

TELEGABEL
FRONT FORK

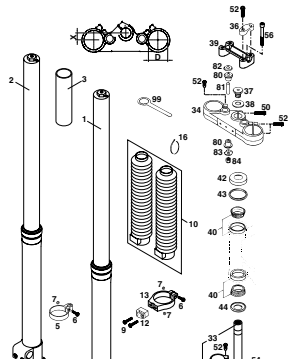

SEITE
Page
3

LENKER, ARMATUREN
HANDLEBAR, CONTROLS

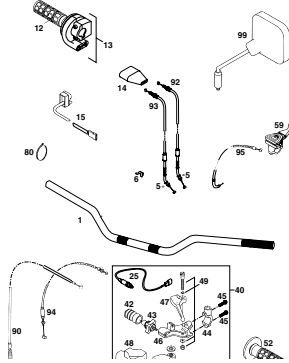

SEITE
Page
4

HANDBREMSZYLINDER
HAND BRAKE CYLINDER

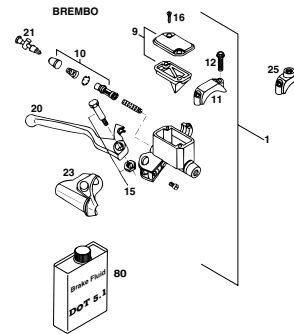

SEITE
Page
5

RAHMEN, AUSLEGER
FRAME, SUB FRAME

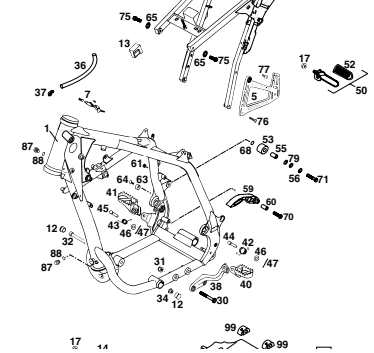

SEITE
Page
6

MITTELSTÄNDER
CENTER STAND

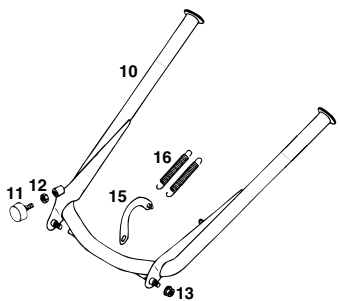

SEITE
Page
8

SCHWINGARM, KETTENSCHUTZ
SWINGARM, CHAIN GUARD

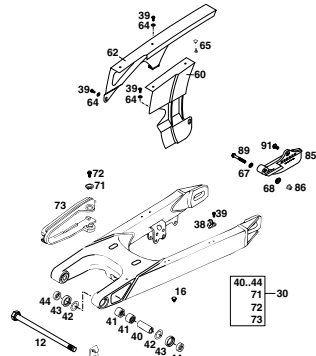

SEITE
Page
9

PRO LEVER ANLENKUNG
PRO LEVER SYSTEM

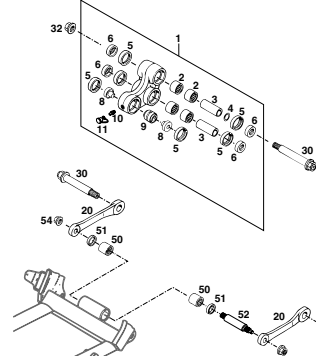

SEITE
Page
10

FUSSBREMSBETÄTIGUNG
REAR BRAKE CONTROL

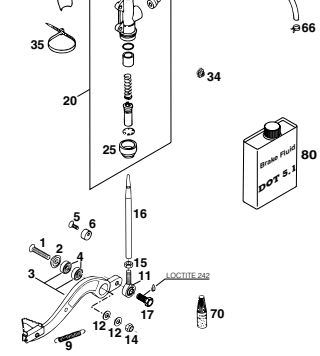

SEITE
Page
11

FEDERBEIN
SHOCK ABSORBER

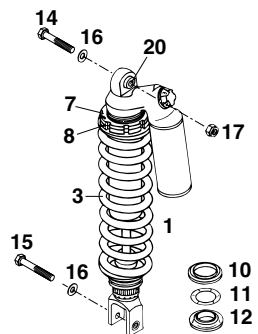

SEITE
Page
12

KRÜMMER, VORSCHALLDÄMPFER
PIPES, PRE SILENCER

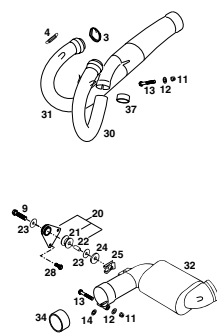

SEITE
Page
13

ENDDÄMPFER
SILENCER

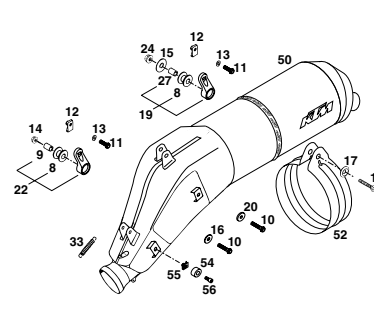

SEITE
Page
14

LUFTFILTERKASTEN
AIR FILTER BOX

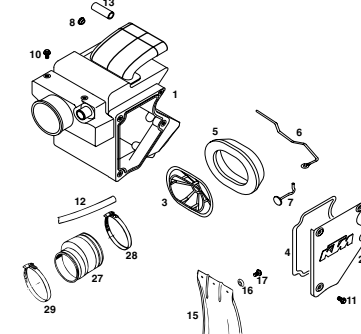

SEITE
Page
15



INHALTSVERZEICHNIS

INDEX

TANK, SITZBANK, VERKLEIDUNG TANK, SEAT, COVER

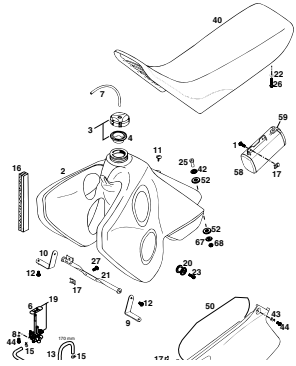

SEITE
Page
16

KOTFLÜGEL, MASKE FENDERS, MASK

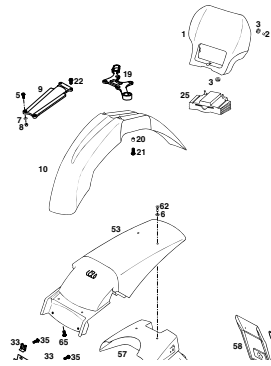

SEITE
Page
18

VORDERRAD FRONT WHEEL

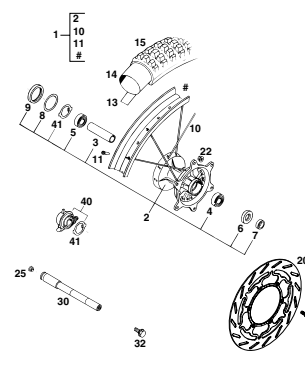

SEITE
Page
19

BREMSZANGE VORNE BRAKE CALIPER FRONT

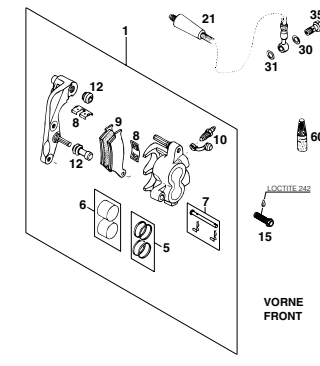

SEITE
Page
20

HINTERRAD REAR WHEEL

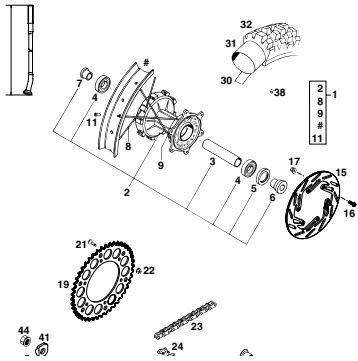

SEITE
Page
21

BREMSZANGE HINTEN BRAKE CALIPER REAR

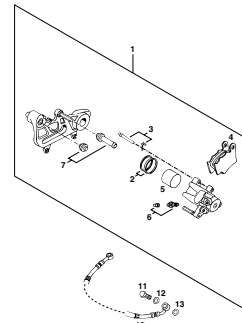

SEITE
Page
22

SCHEINWERFER HEAD LIGHT

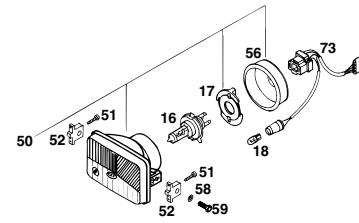

SEITE
Page
23

BLINKER, RÜCKLICHT FLASHER, REAR LIGHT

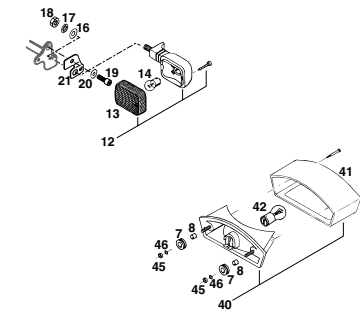

SEITE
Page
24

TACHOANLAGE SPEEDOMETER

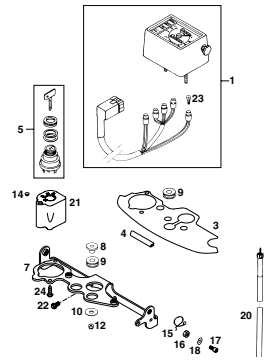

SEITE
Page
25

KABELSTRANG WIRING HARNESS

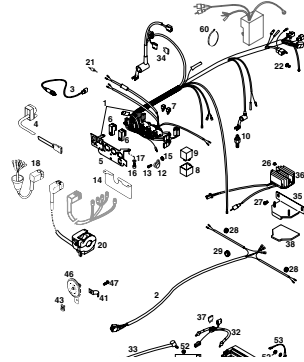

SEITE
Page
26

ZUBEHÖR ACCESSORIES

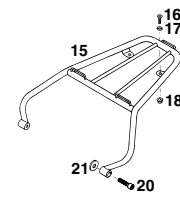

SEITE
Page
28

BORDWERKZEUG TOOL SET

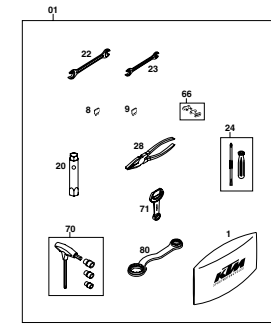

SEITE
Page
29

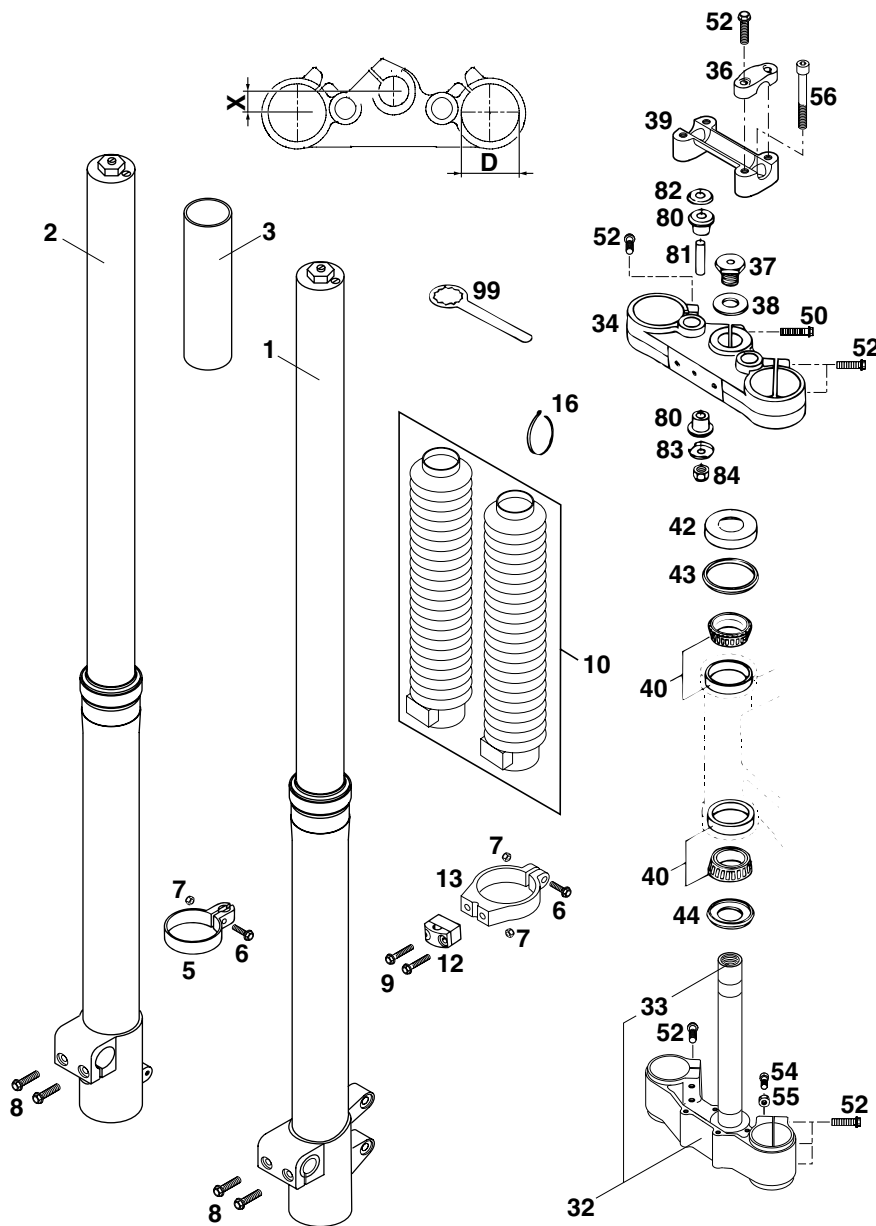

FIG	TEILNR/PARTNR	BEZEICHNUNG	DESCRIPTION	QTY
1*	0918.S776LS	GABELBEIN LI.WP „0918S776“ '98	FORK LEG L/S WP „0918S776“ '98	1
2*	0918.S776RS	GABELBEIN RE.WP „0918S776“ '98	FORK LEG R/S WP „0918S776“ '98	1
3*	579.01.025.000	KUNSTSTOFFROHR SCHWARZ L=150MM	PLASTIC TUBE BLACK L=150MM	2
5	503.01.070.000	TACHOWELLENKLEMMUNG 97	SPEEDOM.CABLE GUIDE D=50MM '97	1
6	0015 050203	SK.BUNDSCHRAUBE M 5X20 SW=8	HH COLLAR SCREW M 5X20 WS=8	2
7	0985 050003	SS.MUTTER DIN0985-M 5	SELF LOCKING NUT DIN0985-M 5	4
8	0015 080253	SK.BUNDSCHRAUBE M 8X25 SW=10	HH COLLAR SCREW M 8X25 WS=10	4
9	0015 050303	SK.BUNDSCHRAUBE M 5X30 SW=8	HH COLLAR SCREW M 5X30 WS=8	2
10	3951085	GARN.MANSCHET. SCHWARZ 50MM WP	GARN. PROTECTORS BLACK 50MM WP	1
12*	546.01.085.000/30	BREMSSCHLAUCHKLEMMME SCHWARZ'98	BRAKE HOSE CLAMP BLACK '98	1
13	503.01.090.250	HALTESCHELLE SCHUTZFÜHRUNG '98	CLAMP PROTECTOR GUIDE '98	1
16	440.11.076.305	KABELBAND 290MM	CABLE TIE 290MM	X
—	440.11.076.200	KABELBAND 200MM	CABLE TIE 200MM	X
32*	579.01.032.016	GABELBR.UNT.KPL. X=16MM/D=50MM SCHWARZ	BOT.TRIPLE CLAMP X=16MM/D=50MM BLACK	1
33	501.01.033.100	GABELSCHAFTRÖHR '91	FORK TUBE L=244 '91	1
34*	579.01.034.016	GABELBRÜCKE OBEN X=16MM/D=50MM SCHWARZ	TOP TRIPLECLAMP X=16MM/D=50MM BLACK	1
36	546.01.038.000	LENKERKLEMMBRÜCKE '95	HANDLEBAR CLAMP '95	2
37	564.01.043.000	SK.SCHRAUBE M20X1,5	HH SCREW M20X1,5	1
38	564.01.044.000	SCHEIBE 21X38X3	WASHER 21X38X3	1
39	583.01.039.100	LENKERAUFNAHME '95	HANDLEBAR SUPPORT '95	1
40	542.01.081.000	KEGELROLLENLAGER SKF 331274	TAPERED ROLL. BEAR. SKF 331274	2
42	542.01.086.000	SCHUTZRING	STEERING HEAD COVER	1
43	546.01.184.000	STEUERKOPFABDICHTUNG OBEN	STEERING HEAD GASKET TOP	1
44	546.01.084.100	O-RINGTRÄGER M. DICHTLIPPE '91	O-RING SUPPORT W. SEALING LIP	1
50	0015 080403	SK.BUNDSCHRAUBE M 8X40 SW=10	HH COLLAR SCREW M 8X40 WS=10	1
52	0015 080303	SK.BUNDSCHRAUBE M 8X30 SW=10	HH COLLAR SCREW M 8X30 WS=10	14
54	0933 080253	SK.SCHRAUBE DIN0933-M 8X25	HH SCREW DIN0933-M 8X25	2
55	0934 080003	SK.MUTTER DIN0934-M 8	HEXAGON NUT DIN0934-M 8	2
56	0984 100703	ZYL.SCHRAUBE DIN6912-M10X70	AH SCREW DIN7984-M10X70	2
80	564.01.040.000	GUMMIBÜCHSE	RUBBER BUSHING	4
81	564.01.041.100	DISTANZROHR 10,2X12X44	SPACER TUBE 10,2X12X44	2
82	564.01.042.000	SCHEIBE 10,5X32X2	WASHER 10,5X32X2	2
83	564.01.142.000	SCHEIBE 10,5X31	WASHER 10,5X31	2
84	0985 100003	SS.MUTTER DIN0985-M10	SELF LOCKING NUT DIN0985-M10	2
99	542.12.035.000	RINGSCHLÜSSEL SW=32	RING WRENCH WS=32	1

* = NEUTEIL / NEW PART

X = NACH BEDARF / AS REQUIRED

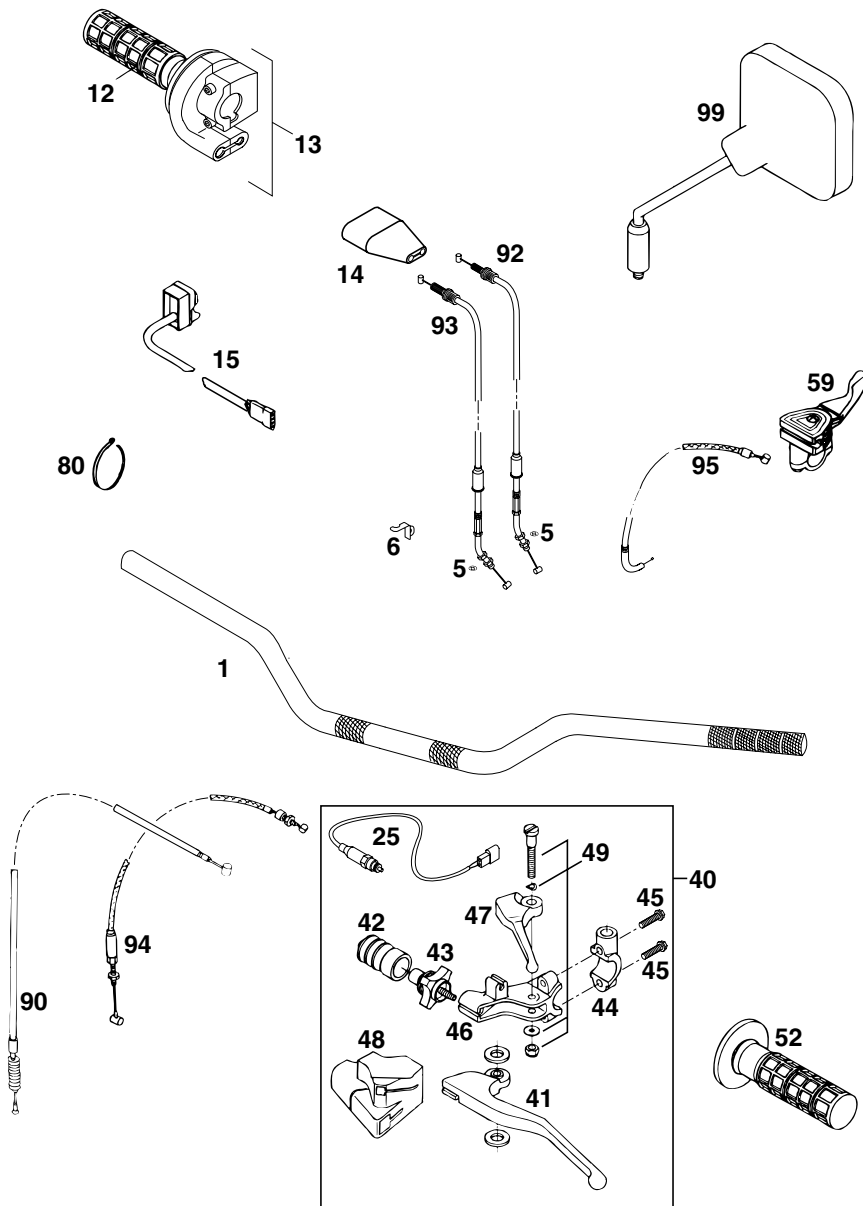

FIG	TEILNR/PARTNR	BEZEICHNUNG	DESCRIPTION	QTY
1	583.02.001.400/30	ALU-LENKER AFAM SCHWARZ '97	HANDLEBAR AFAM BLACK '97	1
5	0799 040000	SICH.SCHEIBE DIN6799-RS 4,0	TAB WASHER DIN6799-RS 4,0	X
6	584.02.093.000	HALBLECH FÜR GASSEIL LC4 '98	BRACKET FOR THROTT.CABLE LC4	X
12	583.02.003.000	DREHGRIFFÜBERZUG DOMINO	TWIST GRIP COVER DOMINO	1
13	584.02.010.400	GASDREHGRIFF KPL.DOMINO-MIKUNI	THROTT.GRIP CPL. DOMINO-MIKUNI	1
14	583.02.016.200	SCHUTZKAPPE RXC/DUKE USA '95	PROTECT.COVER RXC/DUKE USA '95	1
15	584.11.074.000	START NOT-AUS SCHALTER	START-STOP SWITCH	1
25	584.11.049.000	KUPPLUNGSSCHALTER '96	CLUTCH SWITCH '96	1
40	584.02.040.100	KUPPLUNGSHABEL KPL. DOMINO '97	CLUTCH LEVER CPL. DOMINO '97	1
41	584.02.042.000	KUPPLUNGSHABEL LOSE SILBER '97	CLUTCH LEVER LOOSE SILVER '97	1
42	583.02.126.000	FALTENBALG KUPPLUNGSHABEL '95	CLUTCH LEVER BOOT '95	1
43	583.02.043.000	STELLSCHRAUBE KPL. M7	ADJUSTMENT SCREW CPL.M7	1
44	583.02.044.000	KLEMMSCHELLE SPIEGEL M10X1,25	CLAMP MIRROR M10X1,25	1
45	0015 060253	SK.BUNDSCHRAUBE M 6X25 SW=8	HH COLLAR SCREW M 6X25 WS=8	2
46	584.02.041.000	GELENKSTÜCK DOMINO '96	JOINT (PIVOT) DOMINO '96	1
47	583.02.047.000	DEKOHEBEL LOSE	DECOMPRESSION LEVER LOOSE	1
48	584.02.048.000	SCHUTZKAPPE '96	PLASTIC COVER '96	1
49	583.02.049.000	HEBELSCHRAUBE KPL.	LEVER SCREW CPL.	1
52	583.02.052.000	FESTGRIF DOMINO '93	FIXED GRIP DOMINO '93	1
59	583.02.050.000	CHOCKEHEBEL DOMINO '93	CHOKE LEVER DOMINO '93	1
80	440.11.076.200	KABELBAND 200MM	CABLE TIE 200MM	X
80	440.11.076.100	KABELBAND 100MM	CABLE TIE 100MM	X
90	502.02.090.200	KUPPLUNGSSSEIL 125/LC4 TSK '94	CLUTCH CABLE 125/LC4 TSK '94	1
92	584.02.092.000	GASSEIL „AUF“ DOMINO-MIKUNI'98	THROTT.CABLE"OPEN"DOMINO-MIKU.	1
93	584.02.192.000	GASSEIL „ZU“ DOMINO-MIKUNI '98	THROTT.CABLE"CLOSE"DOM.-MIKUNI	1
94	583.02.094.000	HANDDEKOSEIL LC4 '93	DECOMPRESSION CABLE LC4 '93	1
95*	579.02.095.000	KALTSTARTSEIL 640 MILITARY '98	CHOKE CABLE 640 MILITARY '98	1
99	580.12.040.000	RÜCKBLICKSPIEGEL LINKS	REAR MIRROR L/S	1
—	580.12.140.000	RÜCKBLICKSPIEGEL RECHTS	REAR MIRROR R/S	1

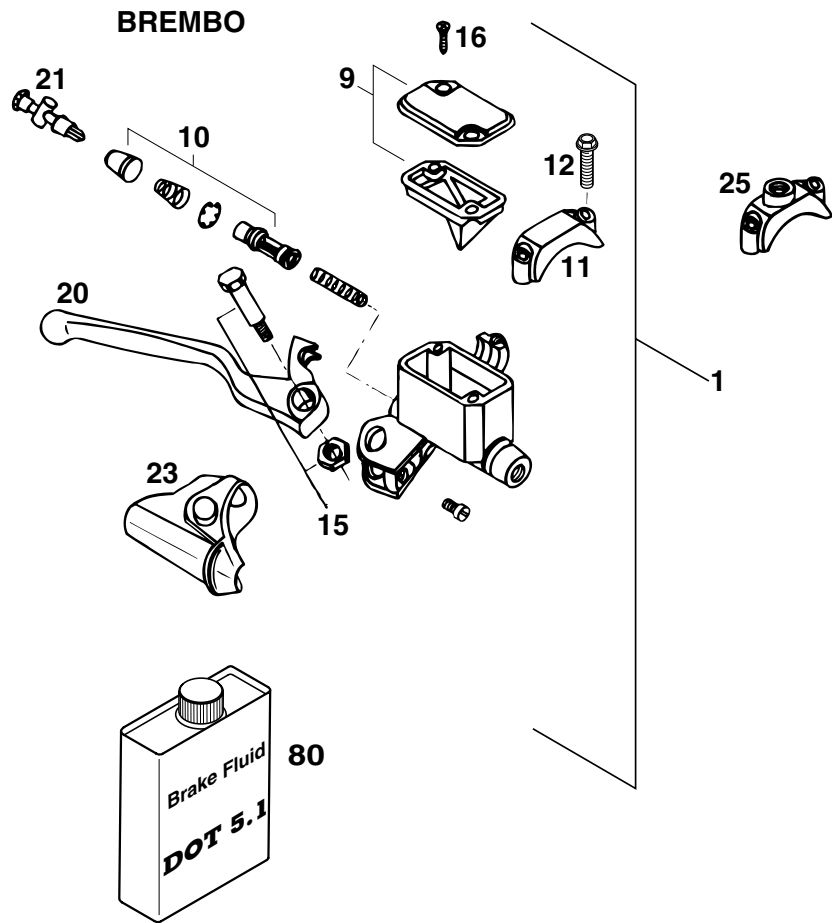

FIG	TEILNR/PARTNR	BEZEICHNUNG	DESCRIPTION	QTY
1	502.13.001.044	HANDBREMSZYLINDER BREMBO'94 D=11MM	HANDBRAKE CYLINDER BREMBO '94 D=11MM	1
9	502.13.012.000	DECKEL KPL.	COVER CPL.	1
10	502.13.050.000	REPARATUR-SATZ KOLBEN 11MM	REPAIR KIT PISTON 11MM	1
11	544.13.011.000	SHELLE	CLAMP	1
12	0015 060253	SK.BUNDSCHRAUBE M 6X25 SW=8	HH COLLAR SCREW M 6X25 WS=8	2
15	502.13.015.000	HEBELSCHRAUBE KPL.	LEVER SCREW CPL.	1
16	0965 050163	SENKSCHRAUBE DIN0965-M 5X16	FLAT HEAD SCREW DIN0965-M 5X16	2
20	502.13.020.000	HANDBREMSHEBEL LOSE BREMBO'94	HAND BRAKE LEVER LOOSE BREM'94	1
21	502.13.021.000	STELLSCHRAUBE KPL.	ADJUSTING SCREW CPL.	1
23	502.13.023.000	SCHUTZKAPPE BREMBO'94	PROTECTION CAP BREMBO'94	1
25	580.12.040.150	KLEMMSCHELLE FÜR SPIEGEL '94	CLAMP FOR MIRROR '94	1
80	306054	BREMSFLÜSSIGKEIT DOT 5.1	BRAKE FLUID DOT 5.1	1

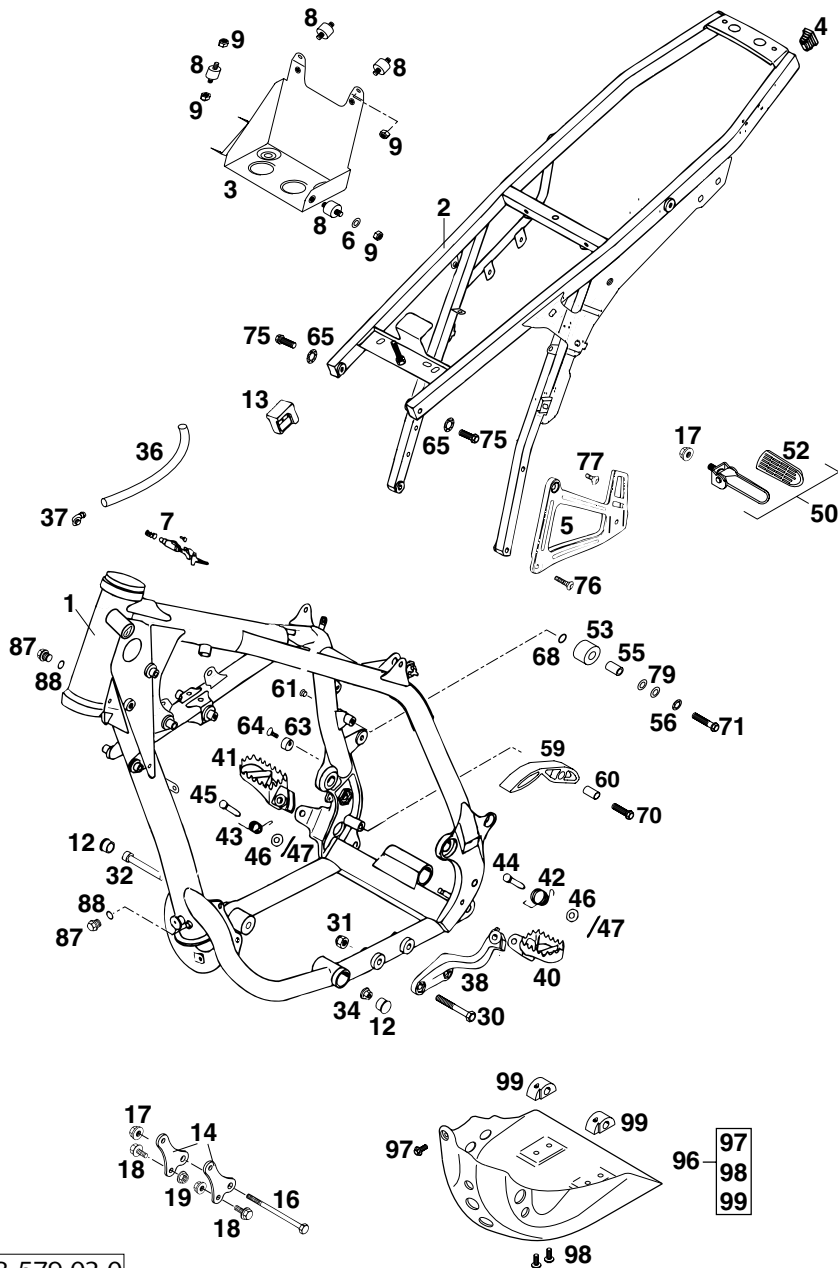

FIG	TEILNR/PARTNR	BEZEICHNUNG	DESCRIPTION	QTY
1*	579.03.001.000	RAHMEN M.ÖLRESERV.MIL.SCHW.'98 MIT LAGER FÜR ANLENKUNG	FRAME W.OILRESERV.MIL.BLACK'98 WITH BEARINGS FOR LINKING	1
2	584.03.002.100/30	AUSLEGER KPL. STAHL SCHWARZ	SUB FRAME CPL. STEEL BLACK	1
3	584.03.002.170	HALTEBLECH F.BATTERIE LC4-E'97	BRACKET FOR BATTERY LC4-E '97	1
4	583.03.002.090	VERSCHLUSSTOPFEN 12 X 17 MM	PLUG 12 X 17 MM	2
5	581.03.003.200/30	FUßRASTENTRÄGER HI.LI. SCHWARZ	FOOTREST BRACKET L/S BLACK	1
-	581.03.004.200/30	FUßRASTENTRÄGER HI.RE. SCHWARZ	FOOTREST BRACKET R/S BLACK	1
6	0137 060000	FEDERSCHEIBE DIN0137-B 6	SPRING WASHER DIN0137-B 6	1
7	710.03.007.000	STEUERKOPFSCHLOSS KPL. ZADI	STEERING HEAD LOCK CPL. ZADI	1
8	584.03.002.010	SILENTBLOCK 20X15-M6X8MM	RUBBER GROMMET 20X15-M6X8MM	4
9	0985 060003	SS.MUTTER DIN0985-M 6	SELF LOCK. NUT DIN0985-M 6	5
12	710.01.012.000	PVC ABSCHLUSSKAPPE D=22MM	PVC CAP D=22MM	2
13	583.07.015.000	TANKAUFLAGE '93	TANK SUPPORT '93	2
14	583.03.055.000	MOTORAUFHÄNGUNG AGW '94	ENGINE SUPPORT AGW '94	2
16	0931 101103	SK.SCHRAUBE DIN0931-M10X110	HH SCREW DIN0931-M10X110	1
17	490.09.082.000	STOVERFLANSCHMUTTER M10 SW=17	SELF LOCKING NUT M10 WS=17	3
18	491.09.481.052	SK.BUNDSCHRAUBE M 8X16	HH COLLAR SCREW M 8X16	4
19	543.10.086.000	STOVERFLANSCHMUTTER M8	SELF LOCKING NUT M8	4
30	0931 100603	SK.SCHRAUBE DIN0931-M10X60	HH SCREW DIN0931-M10X60	2
31	0985 100003	SS.MUTTER DIN0985-M10	SELF LOCKING NUT DIN0985-M10	2
32	0912 101603	ISK.SCHRAUBE DIN0912-M10X160	AH SCREW DIN0912-M10X160	1
34	546.30.044.000	BUNDMUTTER M10 SW=13	COLLAR NUT M10 WS=13	1
36	550.07.016.001	SCHLAUCH 7X10 PER METER	PVC-HOSE 7X10 PER METER	0,3
37	503.03.089.000	WINKELSTÜCK '97	ANGEL PIECE '97	1
38	583.03.038.000/30	FUSSRASTENTRÄGER LINKS SCHWARZ	FOOTREST BRACKET L/S BLACK	1
40	583.03.040.000/30	FUSSRASTE LINKS SCHWARZ	FOOTREST L/S BLACK	1
41	546.03.140.000/30	FUSSRASTE RECHTS SCHWARZ	FOOTREST R/S BLACK	1
42	583.03.041.000	FUSSRASTENFEDER LINKS '93	FOOTREST SPRING L/S '93	1
43	546.03.041.000	FUSSRASTENFEDER LINKS & RECHTS	FOOTREST SPRING L/S & R/S	1
44	583.03.044.000	BOLZEN FÜR FUSSRASTER 9,8 X 43	BOLT FOR FOOTREST 9,8 X 43	1
45	546.03.044.000	BOLZEN FÜR FUSSRASTER 9,8 X 50	BOLT FOR FOOTREST 9,8 X 50	1
46	0125 100003	UNTERLEGSCHIEBE DIN0125-A10,5	WASHER DIN0125-A10,5	2
47	0094 032253	SPLINT DIN0094-3,2X25 STAHL	PIN DIN0094-3,2X25 STEEL	2
50	583.03.050.044	FUSSRASTE HINTEN LINKS KPL.'95	FOOTREST REAR L/S CPL. '95	1
-	583.03.150.044	FUSSRASTE HINTEN RECHTS KPL.'95	FOOT REST REAR R/S CPL. '95	1

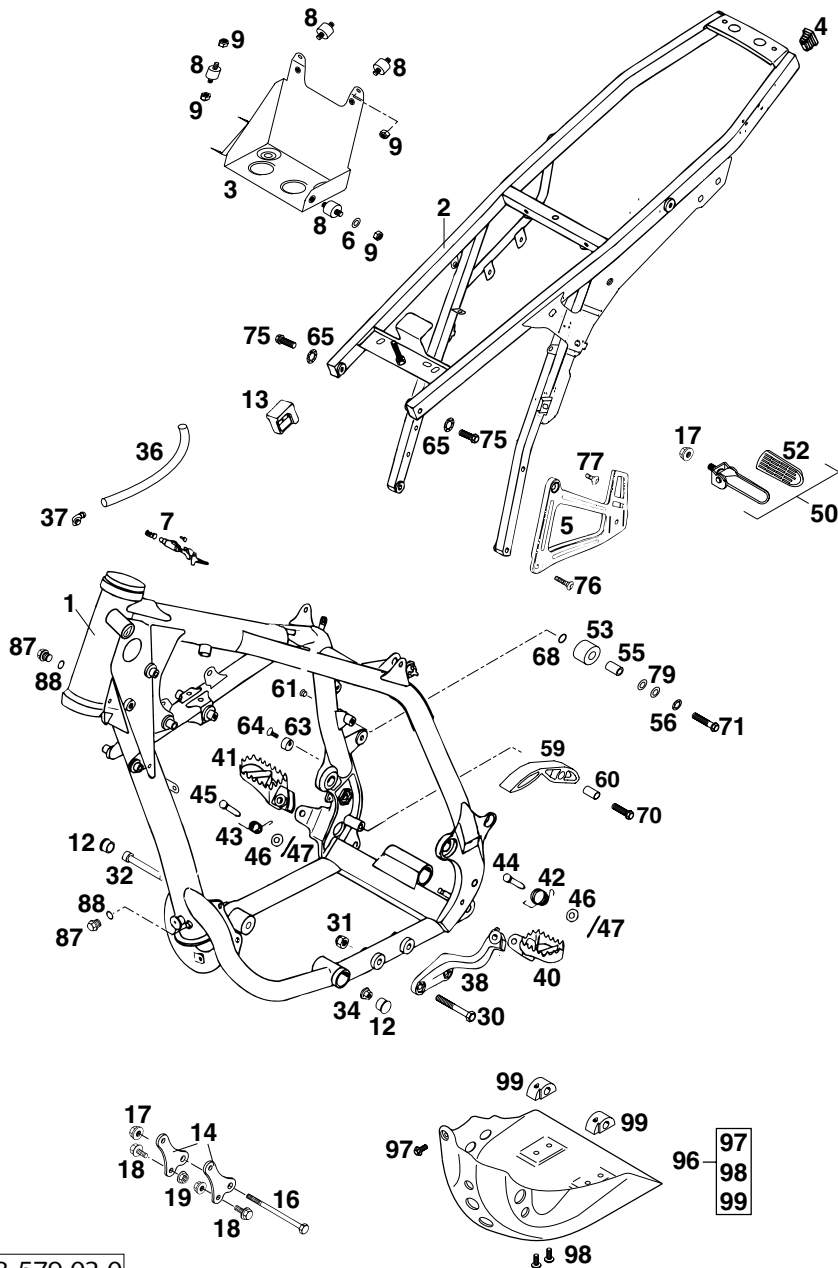
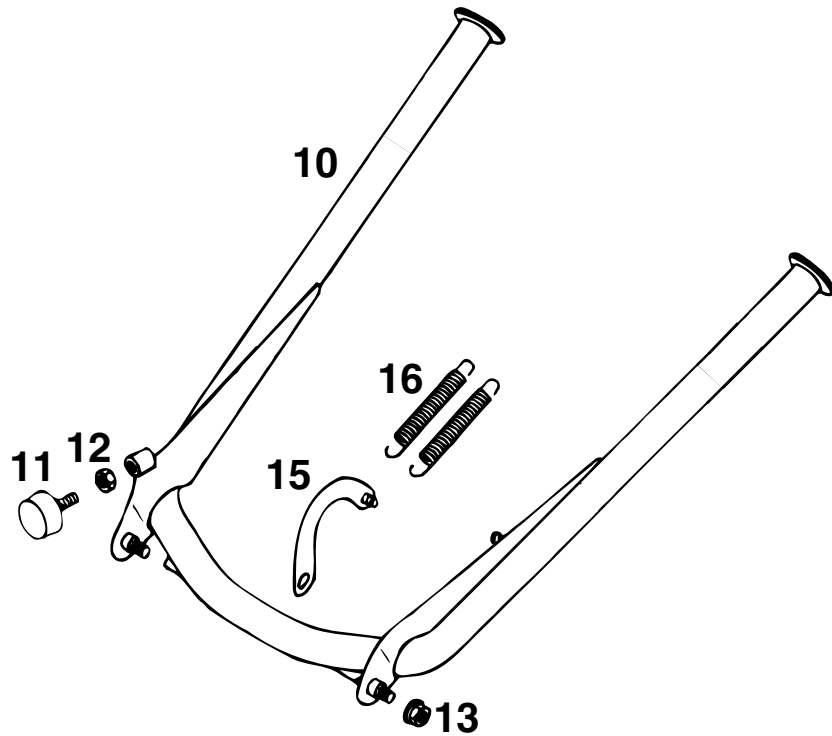

FIG	TEILNR/PARTNR	BEZEICHNUNG	DESCRIPTION	QTY
52	583.03.051.000	FUSSRASTENGUMMI LI&RE DUKE'95	FOOTREST RUBBER L/S&R/S DUKE95	2
53	584.03.060.000	KETTENROLLE 12X28X22 '98	CHAIN ROLL 12X28X22 '98	1
55	584.03.060.065	BÜCHSE KETTENROLLE 8X12X23 '98	BUSH CHAIN ROLL 8X12X23 '98	1
56	0797 080003	ZAHNSCHEIBE DIN6797-J 8,4	TOOTHLOCK WASHER DIN6797-A 8,4	1
59	511.03.053.000	KETTENGLITSTÜCK UNTEN '97	CHAIN SLIDING PIECE BELOW '97	1
60	511.03.053.051	BÜCHSE 8,2X10X20	BUSHING 8,2X10X20	1
61	544.03.135.000	VERSCHLUSSPFROPFEN SFL10	PLASTIC CAP SFL10	1
63	583.03.063.000	BREMSHEBELANSCHLAG '93	BRAKE LEVER STOP '93	1
64	0991 060203	SENKSCHRAUBE DIN7991-M 6X20	FLAT HEAD SCREW DIN7991-M 6X20	1
65	584.11.098.000	KONTAKTSCHIEBE M8 VSV-K8	CONTACT WASHER M8 VSV-K8	2
68	360.03.014.000	SCHNORR-SICHERUNGSSCHIEBE 8MM	LOCK WASHER 8MM	1
70	0015 080303	SK.BUNDSCHRAUBE M 8X30 SW=10	HH COLLAR SCREW M 8X30 WS=10	1
71	0015 080403	SK.BUNDSCHRAUBE M 8X40 SW=10	HH COLLAR SCREW M 8X40 WS=10	1
75	0015 080253	SK.BUNDSCHRAUBE M 8X25 SW=10	HH COLLAR SCREW M 8X25 WS=10	2
76	545.10.052.000	KETTENRADSCHRAUBE-ISK M 8X29	SPROCKET SCREW-AH M 8X26	2
77	0107 080203	ISK.LI.SCHRAUBE DIN0107-M 8X20	AH OVAL H.SCREW DIN0170-M 8X20	2
79	0125 080003	UNTERLEGSCHIEBE DIN0125-A 8,4	WASHER DIN0125-A 8,4	2
87	0910 100003	VERSCHL.SCHR. DIN0910-M10X1	PLUG DIN0910-M10X1	2
88	580.38.022.900	CU-FÜLLRING 10 X 14 X 1,5	CU-SEAL RING 10 X 14 X 1,5	2
96	583.03.005.244	MOTORSCHUTZ KPL. MILITARY '97	ENGINE PROTECTOR CPL. MIL. '97	1
97	0014 060103	SK.BUNDSCHRAUBE M 6X10 SW=8	HH COLLAR SCREW M 6X10 WS=8	1
98	0014 060153	SK.BUNDSCHRAUBE M 6X15 SW=8	HH COLLAR SCREW M 6X15 WS=8	4
99	580.03.012.200	MOTORSCHUTZHALTERUNG RE. '97	ENGINE PROTECTOR BRACKET '97	2

FIG	TEILNR/PARTNR	BEZEICHNUNG	DESCRIPTION	QTY
10	575.03.022.000	MITTELSTÄNDER KURZ L=395MM '93	CENTER STAND SHORT 395MM '93	1
11	583.03.070.000	ANSCHLAGGUMMI M8	STOP RUBBER M8	1
12	0934 080003	SK.MUTTER DIN0934-M 8	HEXAGON NUT DIN0934-M 8	1
13	543.10.086.000	STOVERFLANSCHMUTTER M8	SELF LOCKING NUT M8	2
15	583.03.027.000	FEDERBÜGEL '93	SPRINGBOW '93	1
16	100.03.021.000	STÄNDERFEDER KURZ	STAND SPRING SHORT	2



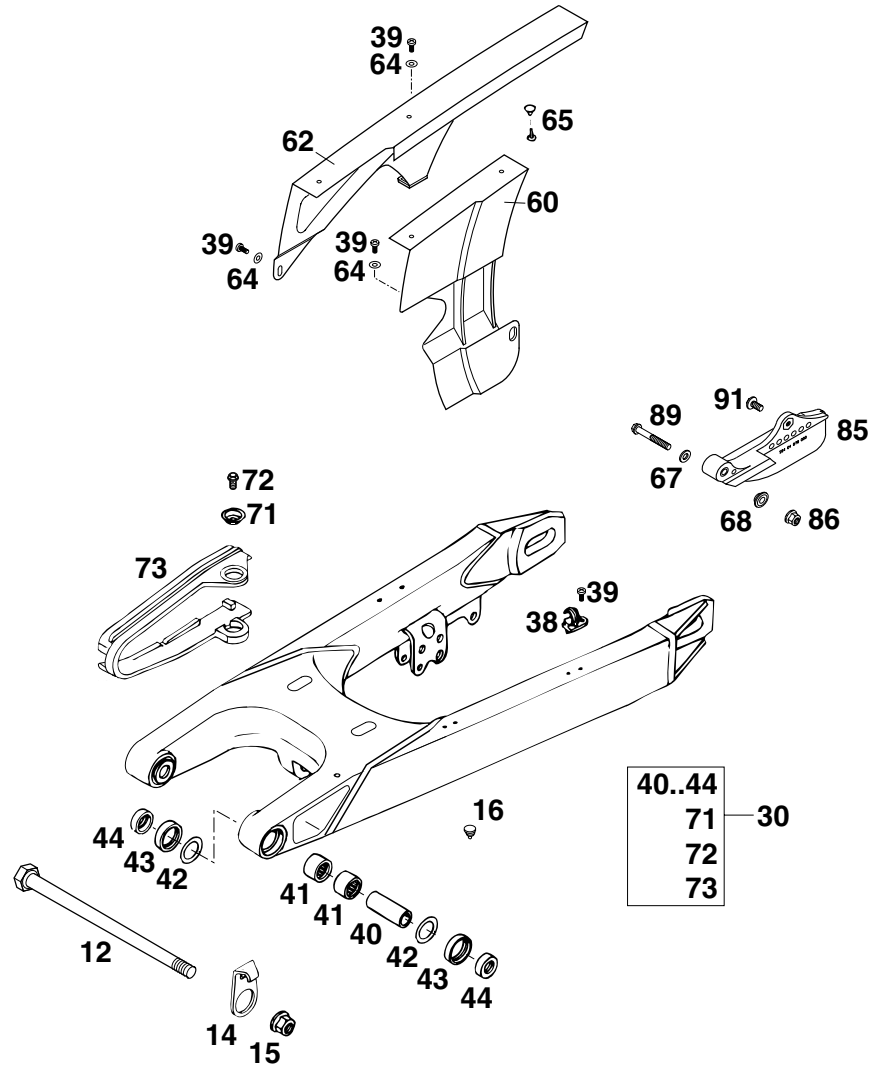

FIG	TEILNR/PARTNR	BEZEICHNUNG	DESCRIPTION	QTY
12	546.03.014.000	SCHWINGARMBOLZEN 15X250	SWINGARM BOLT 15X250	1
14	502.30.211.000	BREMSSCHLAUCHFÜHRUNG '89	BRAKE HOSE GUIDE '89	1
15	546.03.015.000	STOPPMUTTER M14X1,5 SW=19	SELF LOCKING NUT M14X1,5 WS=19	1
16	544.03.135.000	VERSCHLUSSPFROPFEN SFL10	PLASTIC CAP SFL10	X
30	583.03.130.344/30	SCHWINGARM KPL.L=567MM SCHWARZ	SWINGARM CPL. L=567MM BLACK	1
38	546.11.076.100	HALTESCHELLE FÜR BREMSSCHL.'96	RETAIN.CLAMP FOR BRAKE HOSE'96	2
39	0010 050103	GEW.FURCHSCHRAUBE M 5,0X10	SPECIAL SCREW M 5,0X10	5
40	502.03.081.700	LAGERHÜLSE 15X20X38,7	BEARING SLEEVE 15X20X38,7	2
41	502.03.097.000	NADELHÜLSE HK 2012	NEEDLE BUSH HK 2012	4
42	546.03.036.000	ANLAUFSCHLEIBE 22,2X31,7X1	STOP DISK 22,2X31,7X1	2
43	0760 253270	WELLENDICHTRING 25X32X7	SHAFT SEAL RING 25X32X7	4
44	546.03.090.000	TASSE FÜR WELLENDICHTR.15X25X9	BUCKET F.SHAFTSEALRING 15X25X9	4
60	583.07.060.000	KETTENSCHUTZ KLEIN '96	CHAINGUARD SMALL '96	1
62	583.07.060.150	KETTENSCHUTZ GROSS '97	CHAINGUARD LARGE '97	1
64	0125 050003	UNTERLEGSCHLEIBE DIN0125-A 5,0	WASHER DIN0125-A 5,0	3
65	200.12.062.055	HOHLNIET 2-TLG.	HOLLOW RIVET TWO PARTS	2
67	0125 060003	UNTERLEGSCHLEIBE DIN0125-A 6,4	WASHER DIN0125-A 6,4	1
68	584.04.060.050	SCHLEIBE KETTENSCH. 6,5X10X16X6	WASHER CHAINGUARD 6,5X10X16X6	1
71	722.10.079.000	STÜTZSCHALE	BUCKET	2
72	0015 060103	SK.BUNDSCHRAUBE M 6X10 SW=8	HH COLLAR SCREW M 6X10 WS=8	2
73	583.07.073.000	KETTENGLEITSCHUTZ DUKE'94	CHAIN SLIDING GUARD DUKE'94	1
85	584.04.070.000	KETTENFÜHRUNG KPL. HI. LC4 '98	CHAIN GUIDE CPL. REAR LC4 '98	1
86	565.09.064.000	STOVER-FLANSCHMUTTER M6	SELF LOCKING NUT M6	1
89	0015 060503	SK.BUNDSCHRAUBE M 6X50 SW=8	HH COLLAR SCREW M 6X50 WS=8	1
91	0014 060103	SK.BUNDSCHRAUBE M 6X10 SW=8	HH COLLAR SCREW M 6X10 WS=8	1

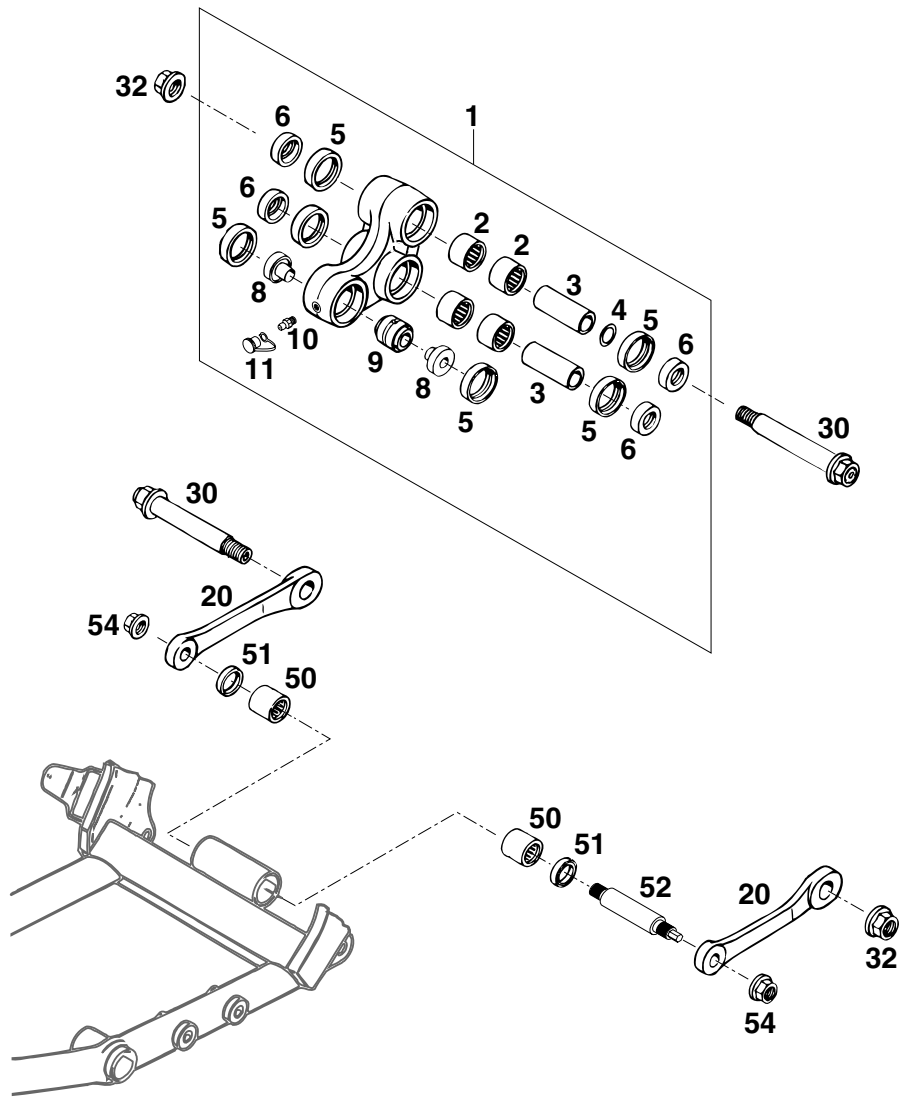

FIG	TEILNR/PARTNR	BEZEICHNUNG	DESCRIPTION	QTY
1	583.03.080.144	WINKELHEBEL KPL. '94	ROCKER ARM CPL. '94	1
2	546.03.097.000	NADELHÜLSE HK 2016	NEEDLE BUSH HK 2016	4
3	546.03.081.000	LAGERHÜLSE 15 X 20 X 48	BEARING SLEEVE 15 X 20 X 48	2
4	546.03.090.010	STAHSCHIBE 15,2X19X0,1	STEEL WASHER 15,2X19X0,1	X
-	546.03.090.020	STAHSCHIBE 15,2X19X0,2	STEEL WASHER 15,2X19X0,2	X
-	546.03.090.030	STAHSCHIBE 15,2X19X0,3	STEEL WASHER 15,2X19X0,3	X
5	0760 253270	WELLENDICHTRING 25X32X7	SHAFT SEAL RING 25X32X7	6
6	583.03.090.000	TASSE F. WELLENDICHTR.15X25X11	SPAC.F.SHAFT SEALRING 15X25X11	4
8	583.03.085.100	BUNDBÜCHSE FÜR GELENKLAGER '95	BUSHING FOR BEARING LINK '95	2
9	542.03.083.050	GELENKLAGER 12X25X22 (16-1061)	LINK BEARING 12X25X22(16-1061)	1
10	720.03.035.000	SCHMIERNIPPEL M6 GERADE	GREASE FITTING M6 STRAIGHT	1
11	530.03.099.000	SCHUTZKAPPE MIT SCHLAUFE ROT	CAP WITH LOOP RED	1
20	583.03.083.000	VERBINDUNGSSTANGE L=127MM '93	LINKAGE ARM L=127MM '93	2
30	546.03.182.050	BOLZEN VERB.STANGE-WINKELHEBEL 15X98MM / M14X1,5	BOLT LINKAGE ARM - ROCKER ARM 15X98MM / M14X1,5	2
32	546.03.015.000	STOPPMUTTER M14X1,5 SW=19	SELF LOCKING NUT M14X1,5 WS=19	2
50	565.03.195.100	NADELLAGER HK 1816	NEEDLE BEARING HK 1816	2
51	0760 182442	WELLENDICHTRING 18X24X4	SHAFT SEAL RING 18X24X4	2
52	583.03.084.100	LAGERBOLZ.VERBINDUNGSSTANGE'96	BEARING BOLT CONNECTING ROD'96	1
54	491.03.415.000	STOV.FLA.MUTTER M12X1,75 SW19	SELF LOCK. NUT M12X1,75 WS=17	2

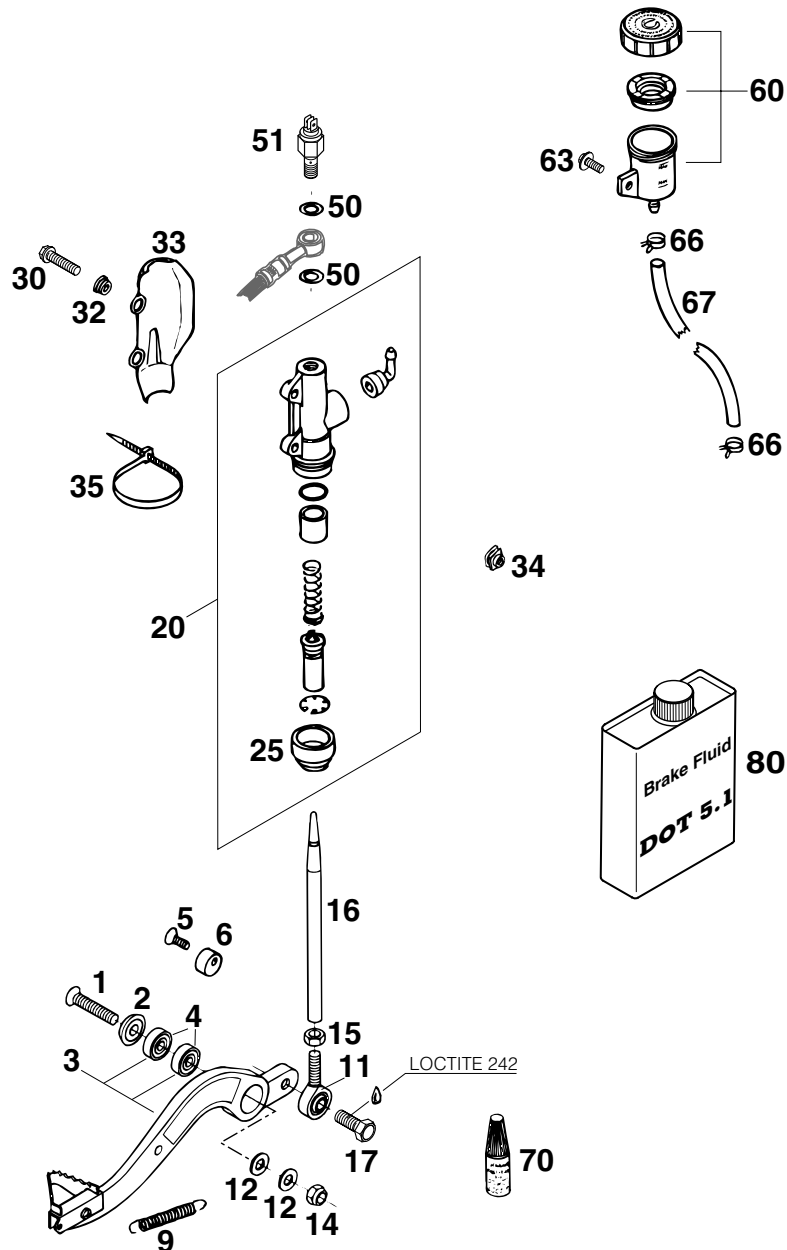

FIG	TEILNR/PARTNR	BEZEICHNUNG	DESCRIPTION	QTY
1	0991 080353	SENKSCHRAUBE DIN7991-M 8X35	FLAT HEAD SCREW DIN7991-M 8X35	1
2	583.03.061.000	FASONSCHIBE ALU 8 X 24 MM	SPECIAL WASHER ALU 8 X 24 MM	1
3	583.03.060.344	FUSSBREMSHEBEL KPL.LC4/ADV.'98	FOOT BRAKE L. CPL. LC4/ADV.'98	1
4	0625 006087	RILLENKUGELLAGER 608 2RS C3	GROOVED BALL BEAR. 608 2RS C3	2
5	0991 060203	SENKSCHRAUBE DIN7991-M 6X20	FLAT HEAD SCREW DIN7991-M 6X20	1
6	583.03.063.000	BREMSHEBELANSCHLAG '93	BRAKE LEVER STOP '93	1
9	130.03.062.000	RÜCKHOLFEDER	RETURN SPRING	1
11	583.03.062.000	GELENKKOPF M8 B=12MM '93	HEIM JOINT M8 W=12MM '93	1
12	0125 080003	UNTERLEGSCHIBE DIN0125-A 8,4	WASHER DIN0125-A 8,4	2
14	0985 080003	SS.MUTTER DIN0985-M 8	SELF LOCKING NUT DIN0985-M 8	1
15	0934 080003	SK.MUTTER DIN0934-M 8	HEXAGON NUT DIN0934-M 8	1
16	583.03.168.000	DRUCKSTANGE ALU L=178MM '93	PUSH ROD ALU L=178MM '93	1
17	0933 080223	SK.SCHRAUBE DIN0933-M 8X22 8.8	HH SCREW DIN0933-M 8X22 8.8	1
20	545.13.101.044	HAUPTBREMSZYLINDER '89	MAIN BRAKE CYLINDER '89	1
25	545.13.151.000	FALTENBALG	RUBBER SLEEVE	1
30	0015 060253	SK.BUNDSCHRAUBE M 6X25 SW=8	HH COLLAR SCREW M 6X25 WS=8	2
32	502.13.161.000	BUNDBÜCHSE	COLLAR BUSHING	2
33	545.13.038.000	BREMSZYLINDERSCHUTZ „BREMBO“	BRAKE CYL. PROTECTOR „BREMBO“	1
34	502.35.033.300	KLIPS-MUTTERNHALTER M6 KP142	SNAP-NUT HOLDER M6 KP142	2
35	440.11.076.305	KABELBAND 290MM	CABLE TIE 290MM	1
50	420.13.226.000	CU-DICHRING DIN7603-10X16X1	CU-SEAL RING DIN7603-10X16X1	2
51	503.11.051.000	BREMSLICHTSCHALTER HINTEN '97	REAR BRAKE LIGHT SWITCH '97	1
60	545.13.030.044	BREMSFLÜSSIGKEITSRESERVIOR '89	BRAKE FLUID RESERVOIR '89	1
63	0014 060103	SK.BUNDSCHRAUBE M 6X10 SW=8	HH COLLAR SCREW M 6X10 WS=8	1
66	580.07.017.000	YDNAC KLAMMER 10101 (9MM)	YDNAC CLAMP 10101 (9MM)	2
67	580.07.016.101	SCHLAUCH FÜR RESERVIOR 6X1,5 GRAU	HOSE FOR RESERVOIR 6X1,5 GREY	0,15
70	6 899 785	LOCTITE 242 BLAU 6CCM	LOCTITE 242 BLUE 6CCM	1
80	306054	BREMSFLÜSSIGKEIT DOT 5.1	BRAKE FLUID DOT 5.1	1

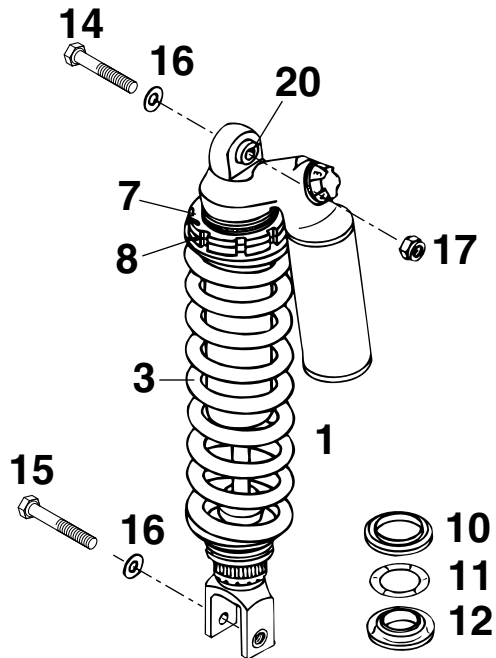

FIG	TEILNR/PARTNR	BEZEICHNUNG	DESCRIPTION	QTY
1	583.04.110.200	MONOSHOCK WP „0118Q784“ '96	MONOSHOCK WP „01187Q784“ '96	1
3	583.04.011.054	FEDER WP 54-260	SPRING WP 54-260	X
3	583.04.011.057	FEDER WP 57-260	SPRING WP 57-260	X
3	583.04.011.060	FEDER WP 60-260	SPRING WP 60-260	X
3	583.04.011.063	FEDER WP 63-260	SPRING WP 63-260	1
3	583.04.011.066	FEDER WP 66-260	SPRING WP 66-260	X
7	542.04.109.000	KONTERMUTTER	COUNTER NUT	1
8	542.04.009.000	EINSTELLMUTTER	ADJUSTING NUT	1
10	583.04.017.000	RING FÜR MONOSHOCK	RING FOR SHOCK ABSORBER	1
11	583.04.090.000	O-RING 32 X 8	O-RING 32 X 8	1
12	583.04.018.000	O-RING TRÄGER 14MM HOCH	O-RING CARRIER 14MM HIGH	1
14	565.03.086.000	SONDERSCHRAUBE M10X47 10.9	SPECIAL SCREW M10X47 10.9	1
15	565.03.093.000	SONDERSCHRAUBE M10X55 10.9	SPECIAL SCREW M10X55 10.9	1
16	0125 100003	UNTERLEGSCHIEBE DIN0125-A10,5	WASHER DIN0125-A10,5	2
17	543.10.086.100	SS.MUTTER M10 CU SW=14	SELF LOCKING NUT M10 CU WS=14	1
20	542.04.020.100	BUCHSE KPL. D=24MM B=24MM	BUSHING CPL. D=24MM B=24MM	1

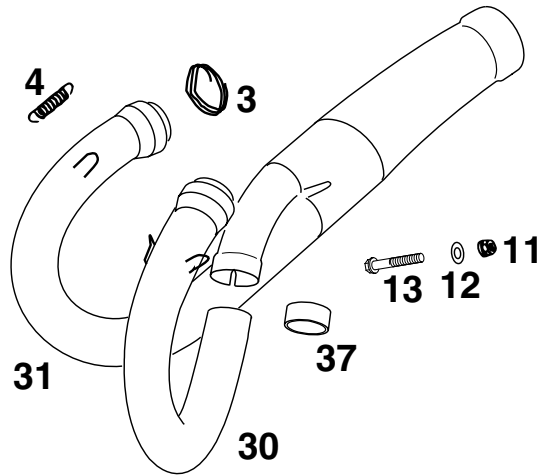

FIG	TEILNR/PARTNR	BEZEICHNUNG	DESCRIPTION	QTY
3	583.05.053.001	KERAMIKSCHNUR 1 METER	CERAMIC LINE 1 METER	1
4	543.09.036.000	ZUGFEDER L=38MM	RETURN SPRING L=38 MM	4
9	0015 080353	SK.BUNDSCHRAUBE M 8X35 SW=10	HH COLLAR SCREW M 8X35 WS=10	1
11	510.10.086.000	SS-MUTTER M 6 CU	SELF LOCKING NUT M 6 COPPER	2
12	0125 060003	UNTERLEGSCHIBE DIN0125-A 6,4	WASHER DIN0125-A 6,4	2
13	0015 060403	SK.BUNDSCHRAUBE M 6X40 SW=8	HH COLLAR SCREW M 6X40 WS=8	2
14	120.11.016.000	SCHEIBE 6 X 12 X 3	WASHER 6 X 12 X 3	1
20	583.05.065.044/30	HALTERUNG-VORSCHALLD. KPL.SCHW	BRACKET-PRE SILENCER CPL.BLACK	1
21	543.05.068.100	DÄMPFUNGSELEMENT SILICON GRAU	DAMPING COMPONENT SILICON GREY	1
22	565.05.069.000	BÜCHSE 8,4X12X16	SPACER BUSHING 8,4X12X16	1
23	0021 080003	SCHEIBE DIN9021-A 8,4	WASHER DIN9021-A 8,4	2
24	510.05.067.000	ISOLIERSCHEIBE 8,5X28X3	INSULATE WASHER 8,5X28X3	1
25	546.03.048.000	MEHRBEREICHSBLECHMUTTER M8	RANGE CHANGE METAL NUT M8	1
28	0015 060163	SK.BUNDSCHRAUBE M 6X16 SW=8	HH COLLAR SCREW M 6X16 WS=8	2
30	577.05.007.100/30	AUSPUFFROHR LINKS SCHWARZ '97	EXHAUST PIPE L/S BLACK '97	1
31	577.05.008.100/30	AUSPUFFROHR RECHTS SCHWARZ '97	EXHAUST PIPE R/S BLACK '97	1
32	584.05.050.200/30	VORSCHALLDÄMPFER „KTM V2“ SCHW.	PRE SILENCER „KTM V2“ BLACK	1
34	584.05.005.001	GRAPHITRING 45X50X25	GRAPHITRING 45X50X25	1
37	577.05.005.000	GRAPHITRING 28X32X20	GRAPHIT RING 28X32X20	1

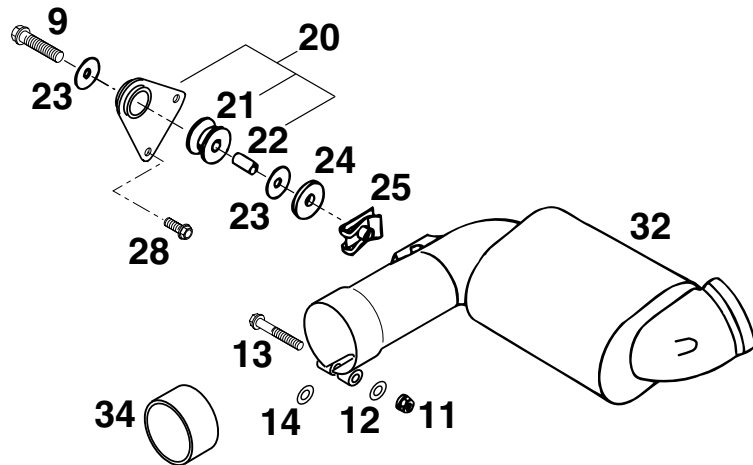
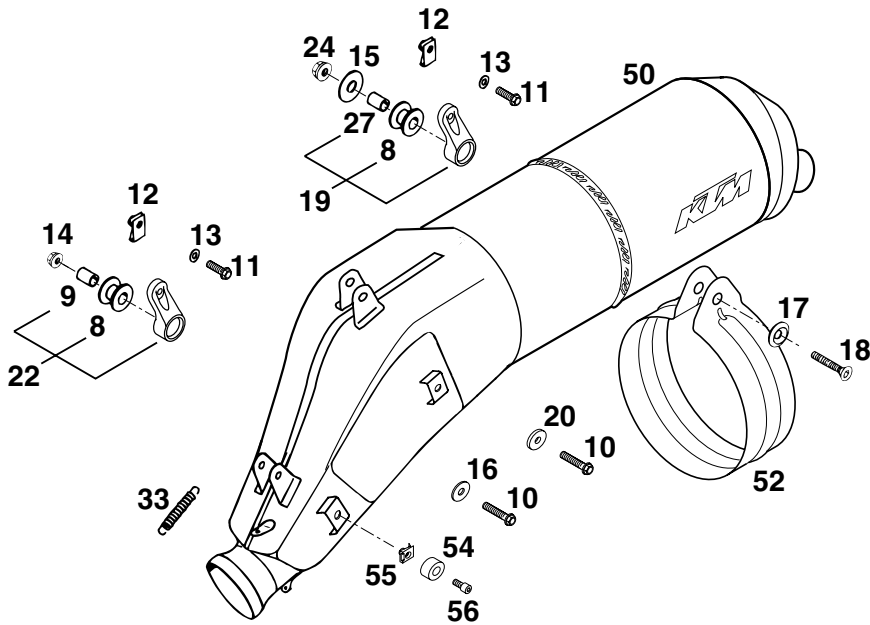

FIG	TEILNR/PARTNR	BEZEICHNUNG	DESCRIPTION	QTY
8	543.05.068.100	DÄMPFUNGELEMENT SILICON GRAU	DAMPING COMPONENT SILICON GREY	3
9	543.05.069.000	BÜCHSE 12 X 7 X 16	BUSHING 12 X 7 X 16	2
10	0015 060303	SK.BUNDSCHRAUBE M 6X30 WS=8	HH COLLAR SCREW M 6X30 WS=8	2
11	0015 060203	SK.BUNDSCHRAUBE M 6X20 WS=8	HH COLLAR SCREW M 6X20 WS=8	3
12	546.03.048.100	MEHRBEREICHSBLECHMUTTER M6	RANGE CHANGE METAL NUT M6	3
13	0137 060000	FEDERSCHEIBE DIN0137-B 6	SPRING WASHER DIN0137-B 6	3
14	565.09.064.000	STOVER-FLANSCHMUTTER M6	SELF LOCKING NUT M6	2
15	0021 080003	SCHEIBE DIN9021-A 8,4	WASHER DIN9021-A 8,4	1
16	0021 060003	SCHEIBE DIN9021-A 6,4	WASHER DIN9021-A 6,4	1
17	583.03.061.000	FASONSCHIBE ALU 8 X 24 MM	SPECIAL WASHER ALU 8 X 24 MM	1
18	0991 080353	SENKSCHRAUBE DIN7991-M 8X35	FLAT HEAD SCREW DIN7991-M 8X35	1
19	583.05.165.144	SCHALLDÄMPFERHALTER KPL. KURZ	SILENCER BRACKET CPL. SHORT	1
20	502.32.050.001	STAHLSCHEIBE 6X17X3	STEEL WASHER 6X17X3	1
22	583.05.165.244	SCHALLDÄMPFERHAL. KPL. KURZ'96	SILENCER BRACKET CPL. SHORT'96	2
24	543.10.086.000	STOVERFLANSCHMUTTER M8	SELF LOCKING NUT M8	1
27	565.05.069.000	BÜCHSE 8,4X12X16	SPACER BUSHING 8,4X12X16	1
33	503.05.016.000	ZUGFEDER L=55MM ÖSEN BEWEGLICH	TENSION SPRING L=55MM	2
50	583.05.083.100/30	ENDDÄMPFER „KTM HGS3“ SCHW.'97	SILENCER „KTM HGS3“ BLACK '97	1
52	583.05.161.100/30	HALTESCHELLE ENDDÄMPF. SCHWARZ	RETAINING CLAMP SILENCER BLACK	1
54	584.05.098.000	GUMMIPUFFER 8X17X10 ENDDÄM.'97	RUBBERBUFFER 8X17X10 SILENC'97	2
55	546.03.048.400	MEHRBEREICHSBLECHMUT. M5 15460	RANGE CHANGE MET. NUT M5 15460	2
56	0912 050123	ISK.SCHRAUBE DIN0912-M 5X12	AH SCREW DIN0912-M 5X12	2



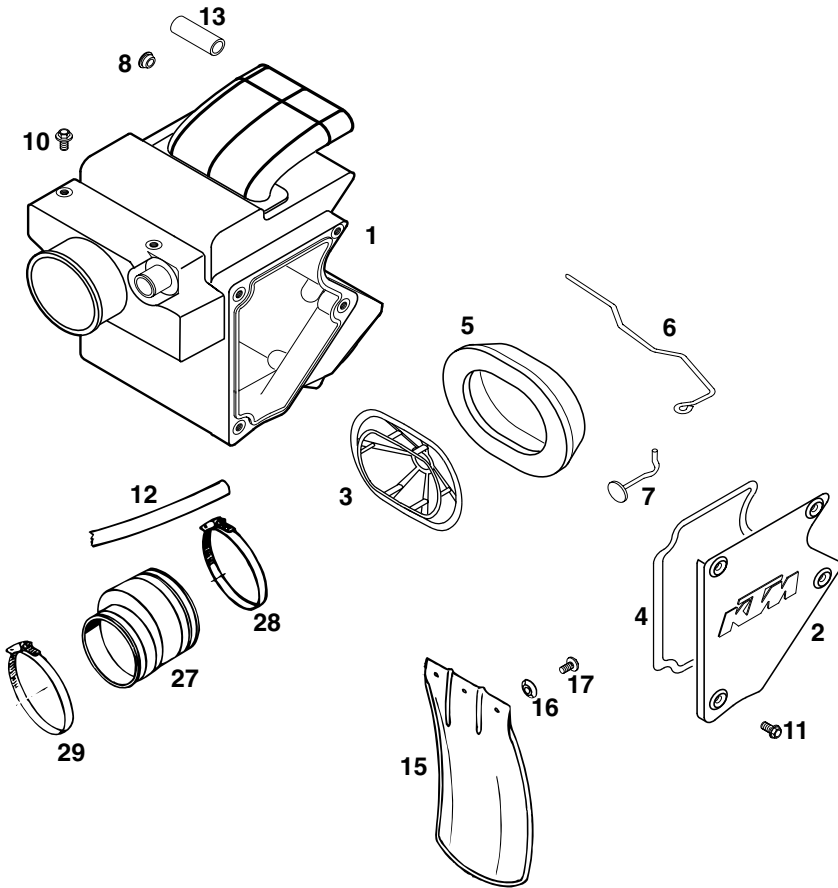

FIG	TEILNR/PARTNR	BEZEICHNUNG	DESCRIPTION	QTY
1	584.06.001.100	FILTERKASTEN KPL. MIT SLS '97	FILTER BOX CPL. WITH SLS '97	1
2	584.06.003.000	FILTERKASTENDECKEL EGS-E '97	FILTER BOX COVER EGS-E '97	1
3	584.06.016.000	FILTERTRÄGER '97	FILTER CARRIER '97	1
4	584.06.090.000	DICHTUNG F.FILTERKASTENDECKEL	GASKET FOR FILTER BOX COVER	1
5	584.06.015.100	FILTERELEMENT E-STARTER '98	FILTERELEMENT E-STARTER '98	1
6	584.06.017.100	HALTEBÜGEL FÜR FILTER '98	HOLDING HANGER FOR FILTER '98	1
7	584.06.017.050	HAKEN FÜR FILTERHALTEBÜGEL '97	HOOK FOR HOLDING HANGER FILTER	1
8	361.11.021.000	VERSCHLUSSPFROPFEN	PLUG	1
10	0014 060103	SK.BUNDSCHRAUBE M 6X10 SW=8	HH COLLAR SCREW M 6X10 WS=8	2
11	0015 050123	SK.BUNDSCHRAUBE M 5X12 SW=8	HH COLLAR SCREW M 5X12 WS=8	4
12	570.05.020.001	SCHLAUCH 10X14 PER METER	HOSE 10X14 PER METER	0,19
13	570.05.020.001	SCHLAUCH 10X14 PER METER	HOSE 10X14 PER METER	0,045
15	546.06.010.000	SPRITZSCHUTZ FÜR FILTERKASTEN	SPLASH PROTECT.FOR FILTER BOX	1
16	722.10.079.000	STÜTZSCHALE	BUCKET	2
17	0014 060103	SK.BUNDSCHRAUBE M 6X10 SW=8	HH COLLAR SCREW M 6X10 WS=8	2
27	584.06.026.000	VERGASERMANSCHETTE 400/640 LC4	AIR FILTER BOOT 400/640 LC4'97	1
28	550.06.028.000	SCHLAUCHBINDER 60-80MM	HOSE CLAMP 60-80MM	1
29	510.06.027.000	SCHLAUCHBINDER 50-70MM	HOSE CLAMP 50-70MM	1

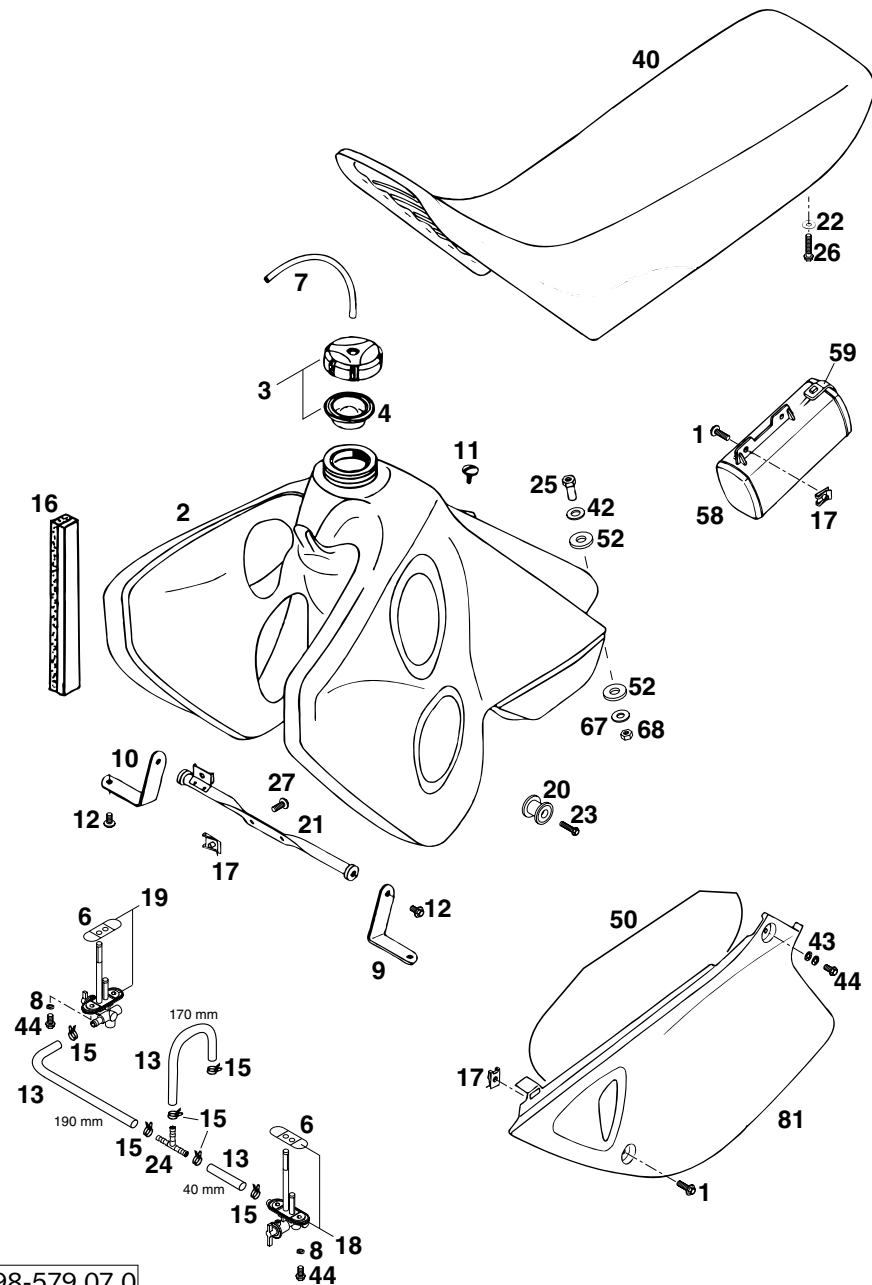
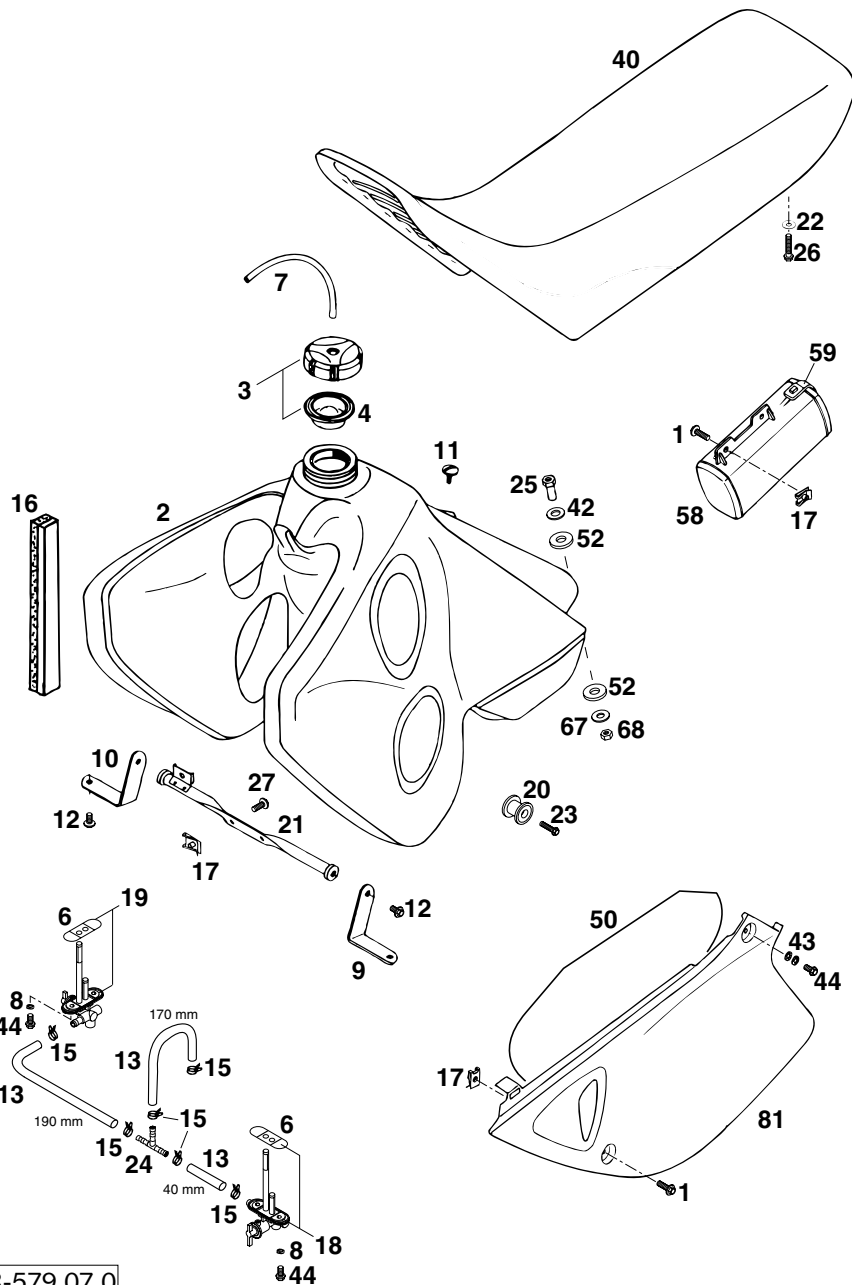

FIG	TEILNR/PARTNR	BEZEICHNUNG	DESCRIPTION	QTY
1	0014 060203	SK.BUNDSCHRAUBE M 6X20 SW=8	HH COLLAR SCREW M 6X20 WS=8	4
2*	583.07.113.100/42	BENZINTANK 20 LITER ROT '98	FUEL TANK 20 LITER RED '98	1
2*	583.07.113.100/60	BENZINTANK 20LI. BRONZEGRÜN'98	FUEL TANK 20LI. BRONZEGREEN'98	1
2*	583.07.113.100/97	BENZINTANK 20 LITER BLAU'98	FUEL TANK 20 LITER BLUE '98	1
3	560.07.008.144	TANKVERSCHLUSS KPL. GROSS	TANK CAP CPL. LARGE	1
4	560.07.009.100	DICHTUNG FÜR TANKVERSCHLUSS	GASKET FOR TANK CAP	1
6	583.07.106.100	DICHTUNG BENZINHAHN MIKUNI	GASKET FUEL COCK MIKUNI	2
7	310.07.107.001	PVC-SCHLAUCH 6X9 MM PER METER	PVC-HOSE 6X9 MM PER METER	0,44
8	0603 061001	CU-DICHRING DIN7603- 6X10X1	CU-SEAL RING DIN7603- 6X10X1	4
9	583.07.121.050/30	TANKHALTEBLECH LINKS SCHWARZ	FUEL TANK BRACKET L/S BLACK	1
10	583.07.121.051/30	TANKHALTEBLECH RECHTS SCHWARZ	FUEL TANK BRACKET R/S BLACK	1
11	580.07.044.000	LINSENSCHRAUBE M6X15 250/4T	OVAL HEAD SCREW M6X15 250/4T	1
12	0014 060103	SK.BUNDSCHRAUBE M 6X10 SW=8	HH COLLAR SCREW M 6X10 WS=8	4
13	544.35.024.001	ND-SCHLAUCH ID 7,5 PER METER	HOSE ID 7,5 PER METER	0,4
15	580.31.005.000	YDNAC KLAMMER 10128	CLAMP YDNAC 10128	5
16	581.07.011.000	SCHAUMSTOFFSTREIFEN SELBSTKL.	FOAM RUBBER STRIP	2
17	546.03.048.100	MEHRBEREICHSBLECHMUTTER M6	RANGE CHANGE METAL NUT M6	6
18	583.07.005.100	BENZINHAHN MIKUNI CK-84 '96 EIN ANSCHLUSS	FUEL COCK MIKUNI CK-84 '96 ONE CONNECTION	1
19	511.07.004.000	BENZINHAHN KPL.MIKUNI CK-69'96 EIN ANSCHLÜSSE	FUEL COCK CPL.MIKUNI CK-69 '96 ONE CONNECTIONS	1
20	583.07.113.250	TANKROLLE KPL. 12 X 34 X 25	TANK BUSHING CPL. 12 X 34 X 25	2
21	583.07.121.000/30	TANKSTREBE 20 LI.TANK SCHWARZ	FUEL TANK LINK 20 LI. BLACK	1
22	0125 060003	UNTERLEGSCHLEIBE DIN0125-A 6,4	WASHER DIN0125-A 6,4	1
23	0015 060253	SK.BUNDSCHRAUBE M 6X25 SW=8	HH COLLAR SCREW M 6X25 WS=8	2
24	580.07.015.000	T-STÜCK FÜR BENZINLEITUNG	T-CONNECTOR FOR FUEL LINE	1
25	583.07.014.000	HALSMUTTER M8	SPECIAL NUT M8	1
26	0015 060303	SK.BUNDSCHRAUBE M 6X30 SW=8	HH COLLAR SCREW M 6X30 WS=8	1
27	0014 060153	SK.BUNDSCHRAUBE M 6X15 SW=8	HH COLLAR SCREW M 6X15 WS=8	2
40	583.07.140.700/30	SITZBANK BREIT SCHWARZ '97	SEAT WIDE BLACK '97	1
42	583.07.019.000	SCHEIBE 10,5 X 25 X 1,5	WASHER 10,5 X 25 X 1,5	1
43	502.33.041.000	NORDLOCK SCHEIBEN M6 (PAAR)	PAIR OF WASHERS M6 NORDLOCK	2
44	0015 060123	SK.BUNDSCHRAUBE M 6X12 SW=8	HH COLLAR SCREW M 6X12 WS=8	6
50	583.08.041.050	HITZESCHUTZ ZUSCHNITT	HEAT PROTECTOR	1
52	510.05.067.100	ISOLIERSCHEIBE 12X28X3	INSULATE WASHER 12X28X3	2

FIG	TEILNR/PARTNR	BEZEICHNUNG	DESCRIPTION	QTY
58	580.12.058.000	WERKZEUGKASTEN KPL. '92	TOOL BOX CPL. '92	1
59	580.12.058.050	GUMMI FÜR WERKZEUGKASTEN '92	RUBBER FOR TOOL BOX '92	1
67	0021 080003	SCHEIBE DIN9021-A 8,4	WASHER DIN9021-A 8,4	1
68	0934 080003	SK.MUTTER DIN0934-M 8	HEXAGON NUT DIN0934-M 8	1
81*	583.08.041.000/42	SEITENVERKL. LINKS ROT '98	SIDE COVER L/S RED '98	1
81*	583.08.041.000/60	SEITENVERKL. LI. BRONZEGRÜN'98	SIDE COVER L/S BRONZEGREEN '98	1
81*	583.08.041.000/97	SEITENVERKL. LINKS BLAU '98	SIDE COVER L/S BLUE '98	1
—*	583.08.042.000/42	SEITENVERKL. RECHTS ROT '98	SIDE COVER R/S RED '98	1
—*	583.08.042.000/60	SEITENVERKL. RE. BRONZEGRÜN'98	SIDE COVER R/S BRONZEGREEN '98	1
—*	583.08.042.000/97	SEITENVERKL. RECHTS BLAU '98	SIDE COVER R/S BLUE '98	1



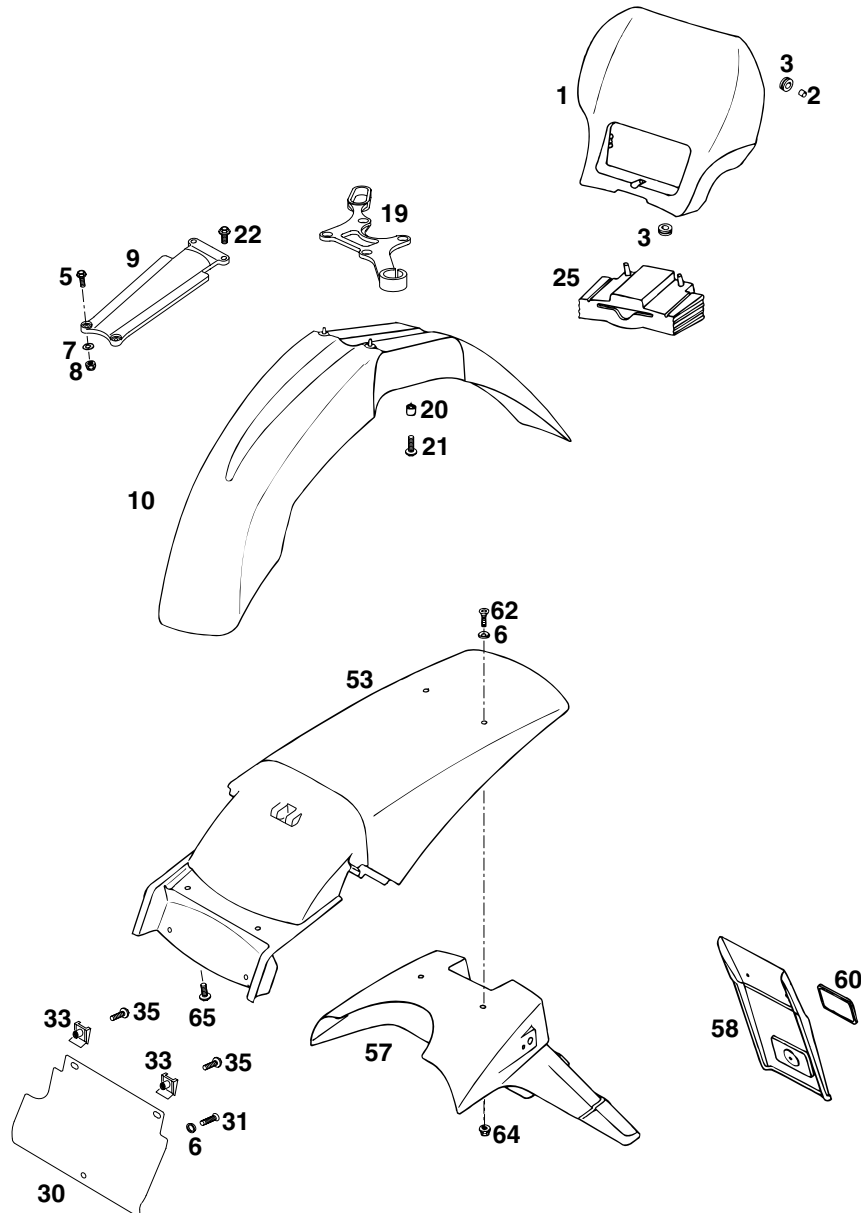

FIG	TEILNR/PARTNR	BEZEICHNUNG	DESCRIPTION	QTY
1*	502.11.401.000/42	SCHEINWERFERMASKE ROT '98	HEAD LIGHT MASK RED '98	1
1*	502.11.401.000/60	SCHEINW.MASKE BRONZEGRÜN '98	HEAD LIGHT MASK BRONZEGREEN'98	1
1*	502.11.401.000/97	SCHEINWERFERMASKE BLAU '98	HEAD LIGHT MASK BLUE '98	1
2	580.11.039.000	DISTANZBÜCHSE 6,5 X 8 X 7	SPACER BUSHING 6,5 X 8 X 7	2
3	310.08.060.000	KABELTÜLLE D=8MM OFFEN	RUBBER SLEEVE D=8MM OPEN	4
5	0015 050163	SK.BUNDSCHRAUBE M 5X16 SW=8	HH COLLAR SCREW M 5X16 WS=8	2
6	400.06.006.000	FASSONSCHIBE 6MM	WASHER 6MM	3
7	0021 050003	SCHEIBE DIN9021-A 5,3	WASHER DIN9021-A 5,3	2
8	0985 050003	SS.MUTTER DIN0985-M 5	SELF LOCKING NUT DIN0985-M 5	2
9	503.08.009.000	KOTFLÜGELSTREBE SCHWARZ '97	FENDER BRACE BLACK '97	1
10*	502.08.410.000/42	VORDERRADKOTFLÜGEL ROT '98	FRONT FENDER RED '98	1
10*	502.08.410.000/60	VORDERRADKOTFL. BRONZEGRÜN '98	FRONT FENDER BRONZEGREEN '98	1
10*	502.08.410.000/97	VORDERRADKOTFLÜGEL BLAU '98	FRONT FENDER BLUE '98	1
19	503.08.019.000	TACHOWELLENFÜHRUNG 125-380 '98	SPEEDO.CABLE GUIDE 125-380 '98	1
20	502.08.020.000	DISTANZBÜCHSE 7X10X7,5	SPACER BUSHING 7X10X7,5	4
21	0014 060203	SK.BUNDSCHRAUBE M 6X20 SW=8	HH COLLAR SCREW M 6X20 WS=8	4
22	0014 060153	SK.BUNDSCHRAUBE M 6X15 SW=8	HH COLLAR SCREW M 6X15 WS=8	2
25	502.11.402.000	DISTANZSTÜCK FÜR MASKE '93	SPACER FOR HEADLIGHT MASK '93	1
30	583.08.013.250	KOTFLÜGELVERLÄNGERUNG LC4-E'97	FENDER EXTENSION LC4-E '97	1
31	0016 055163	PLASTITE SCHRAUBE Z 5,5X16	SPECIAL SCREW Z 5,5X16	1
33	546.03.048.100	MEHRBEREICHBLECHMUTTER M6	RANGE CHANGE METAL NUT M6	2
35	0014 060153	SK.BUNDSCHRAUBE M 6X15 SW=8	HH COLLAR SCREW M 6X15 WS=8	2
53*	583.08.013.200/42	KOTFLÜGEL HINTEN ROT '98	REAR FENDER RED '98	1
53*	583.08.013.200/60	KOTFLÜGEL HINTEN BRONZEGRÜN'98	REAR FENDER BRONZEGREEN '98	1
53*	583.08.013.200/97	KOTFLÜGEL HINTEN BLAU '98	REAR FENDER BLUE '98	1
57	583.08.013.051	NUMMERTAFELTRÄGER EGS '93	NUMBER PLATE CARRIER EGS '93	1
58	490.08.216.000	VERLÄNGERUNG F.NUMMERTAFELTR.	EXTENSION FOR NUMBER PLATE	1
60	510.12.180.000	RÜCKSTRAHLER ROT GEKLEBT	REFLECTOR SELF-ADHESIV RED	1
62	0991 060203	SENKSCHRAUBE DIN7991-M 6X20	FLAT HEAD SCREW DIN7991-M 6X20	2
64	565.09.064.000	STOVER-FLANSCHMUTTER M6	SELF LOCKING NUT M6	2
65	0014 060153	SK.BUNDSCHRAUBE M 6X15 SW=8	HH COLLAR SCREW M 6X15 WS=8	2

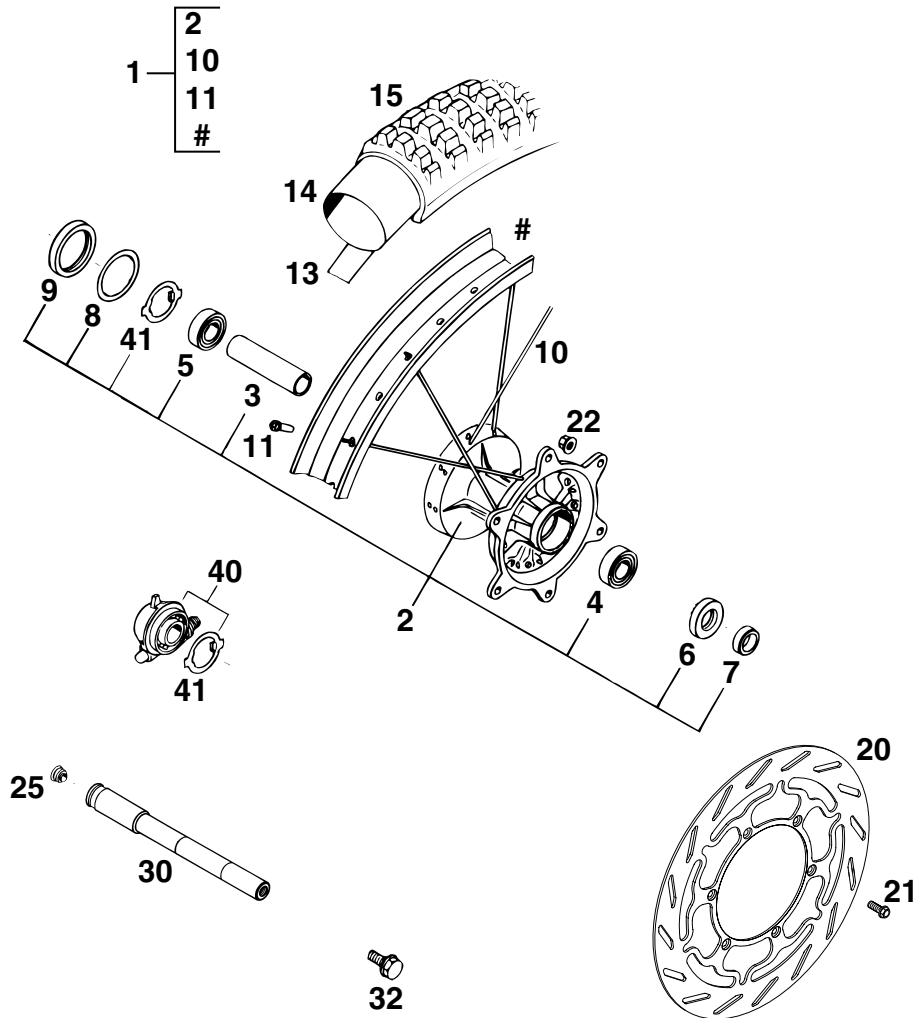
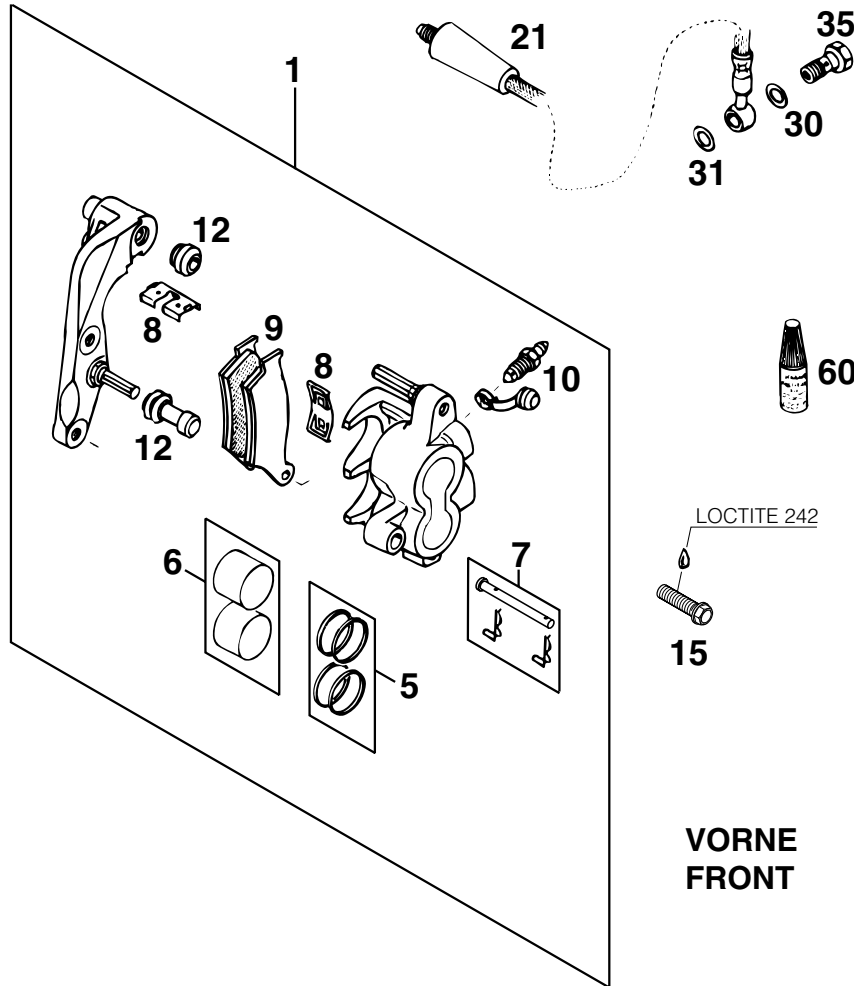

FIG	TEILNR/PARTNR	BEZEICHNUNG	DESCRIPTION	QTY
1	580.09.001.144/30	VORDERRAD 1,6X21" DID SCHWARZ	FRONT WHEEL 1,6X21" DID BLACK	1
2	546.09.010.044/30	VORDERRADNABE KPL. SCHWARZ '97	FRONT HUB CPL. BLACK '97	1
3	546.09.011.000	LAGERDISTANZROHR 17,5X22X64,5	BEAR.SPACER TUBE 17,5X22X64,5	1
4	0625 060037	RILLENKUGELLAGER 6003 2SR C3	GROOVED BALL BEAR. 6003 2SR C3	1
5	0625 062032	RILLENKUGELLAGER 6203 2RS C3	GROOVED BALL BEAR. 6203 2RS C3	1
6	0760 253570	WELLENDICHTRING 25X35X7 BTSL	SHAFT SEAL RING 25X35X7 BTSL	1
7	546.09.051.000	DISTANZRING 17X25X7,5	SPACER RING 17X25X7,5	1
8	581.11.054.000	SCHEIBE 40 X 52 X 0,15 '92	WASHER 40 X 52 X 0,15 '92	1
9	0760 405270	WELLENDICHTRING 40X52X7 B	SHAFT SEAL RING 40X52X7 B	1
10	583.09.071.234/30	SPEICHE M5X234-15G 21" SCHWARZ	SPOKE M5X234-15G 21" DDE BLACK	36
11	565.09.072.000/30	STAHLNIPPEL M5 SCHWARZ VERZ.	STEEL NIPPLE M5 BLACK	36
13	510.09.073.000	FELGENBAND 21"	RIM BAND 21"	1
14	510.09.075.000	SCHLAUCH 3.00/3.25 90/90-21"	HOSE 3,00/3,25 90/90-21"	1
15	582.09.074.000	REIFEN 90/90-21" 54S ENDURO 3	TYRE 90/90-21" 54S ENDURO 3	1
20	583.09.060.100	BREMSSCHEIBE VORNE D=300MM '96	BRAKE DISK FRONT D=300MM '96	1
21	0015 060163	SK.BUNDSCHRAUBE M 6X16 SW=8	HH COLLAR SCREW M 6X16 WS=8	6
22	565.09.064.000	STOVER-FLANSCHMUTTER M6	SELF LOCKING NUT M6	6
25	550.09.086.000	VERSCHLUSSPFROPFEN SFL13	PLUG SFL13	1
30	503.09.081.000	STECKACHSE VORNE L=235MM	FRONT AXLE L=235MM	1
32	490.32.011.000	SK.BUNDSCHRAUBE M10X20	HH COLLAR SCREW M10X20	1
40	581.11.052.100	TACHOANTRIEB 748217 (3,0)	SPEEDOMETER DRIVE 748217 (3,0)	1
41	581.11.053.100	MITNEHMER FÜR TACHOANTRIEB '92	DRIVING DOG F.SPEEDOM.DRIVE'92	1

FIG	TEILNR/PARTNR	BEZEICHNUNG	DESCRIPTION	QTY
1	584.13.015.044	BREMSZANGE VO. KPL. 2KOLBEN'98	BRAKE CALI.FRONT CPL. 2 PISTON	1
5	546.13.205.000	REPARATURSATZ 28MM	REPAIR KIT 28MM	1
6	546.13.206.000	REPARATUR SATZ KOLBEN 28MM	REPAIR KIT PISTON 28MM	1
7	546.13.210.100	BOLZEN KPL. 6X56	BOLT CPL. 6X56	1
8	546.13.212.000	HALTEBLECHE GARNITUR BREMBO	RETAINING PLATE SET BREMBO	1
9	584.13.030.000	GARN.BREMSKLÖTZE TEXTART4069GF	BRAKE PAD SET TEXTAR T4069 GF	1
10	545.13.214.000	ENTLÜFTUNGSSCHRAUBE M10X1	BLEEDER SCREW M10X1	1
12	546.13.218.000	MANSCHETTENSATZ	CUP SET SHORT	1
15	0015 080353	SK.BUNDSCHRAUBE M 8X35 SW=10	HH COLLAR SCREW M 8X35 WS=10	2
21*	579.13.011.000	BREMSSCHLAUCH VORNE MILITARY	BRAKE HOSE FRONT MILITARY	1
30	420.13.226.000	CU-DICHTRING DIN7603-10X16X1	CU-SEAL RING DIN7603-10X16X1	1
31	420.13.026.000	CU-DICHTRING DIN7603-10X16X1,5	CU-SEAL RING DIN7603-10X16X1,5	1
35	502.13.025.000	HOHLSCHRAUBE M10X1X19	HOLLOW SCREW M10X1X19	1
60	6 899 785	LOCTITE 242 BLAU 6CCM	LOCTITE 242 BLUE 6CCM	1



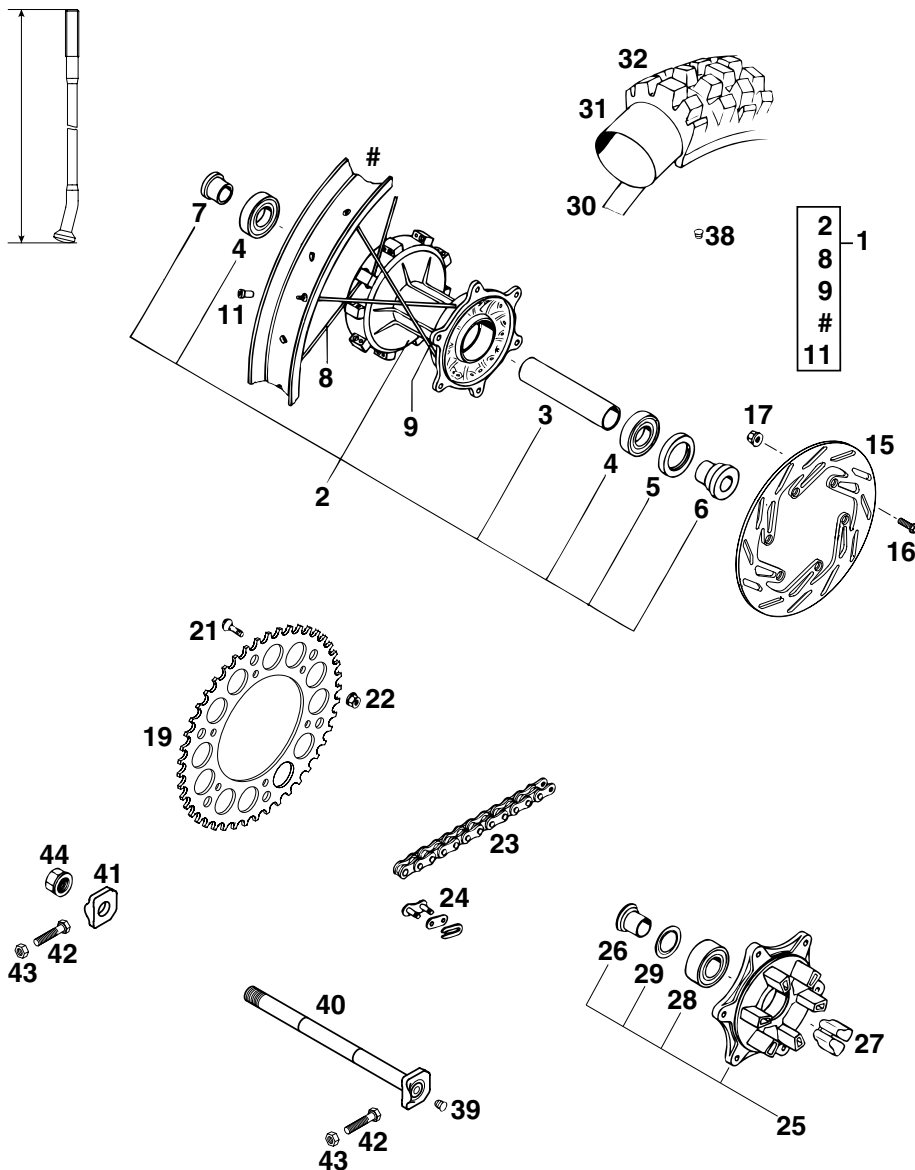

FIG	TEILNR/PARTNR	BEZEICHNUNG	DESCRIPTION	QTY
1	583.10.001.044/30	HINTERRAD 2,50X18" DID SCHWARZ	REAR WHEEL 2,50X18" DID BLACK	1
2	583.10.010.044/30	HINTERRADNABE GED. SCHWARZ	REAR WHEEL HUB DAMPED BLACK	1
3	546.10.411.100	LAGERDISTANZROHR L=98,5MM	BEARING SPACER TUBE L=98,5MM	1
4	0625 062052	RILLENKUGELLAGER 6205 2RSR C3	GROOVED BALL BEAR. 6205 2RSRC3	2
5	0760 325272	WELLENDICHTRING 32X52X7 B	SHAFT SEAL RING 32X52X7 B	1
6	546.10.016.000	BÜCHSE FÜR NABE	BUSHING FOR HUB	1
7	546.10.416.300	BÜCHSE FÜR HR.NABE GEDÄMPFT	BUSHING FOR REAR DAMPED HUB	1
8	546.10.471.000/30	SPEICHE M5X223-10G 18" SCHWARZ	SPOKE M5X223-10G 18" BLACK	18
9	565.10.171.600/30	SPEICHE M5X198-10G 18" SCHWARZ	SPOKE M5X198-10G 18" BLACK	18
11	565.09.072.000/30	STAHLNIPPEL M5 SCHWARZ VERZ.	STEEL NIPPLE M5 BLACK	36
15	580.10.060.600	BREMSSCHEIBE 220MM ANGESENKT	REAR BRAKE DISK 220MM COUNTERS	1
16	0015 060203	SK.BUNDSCHRAUBE M 6X20 SW=8	HH COLLAR SCREW M 6X20 WS=8	6
17	565.09.064.000	STOVER-FLANSCHMUTTER M6	SELF LOCKING NUT M6	6
19*	583.10.051.042/30	KETTENRAD 42-Z SCHWARZ	SPROCKET 42-T BLACK	1
21	545.10.052.000	KETTENRADSCHRAUBE-ISK M 8X29	SPROCKET SCREW-AH M 8X29	6
22	543.10.086.000	STOVERFLANSCHMUTTER M8	SELF LOCKING NUT M8	6
23	500.10.065.100	O-RING KETTE 5/8X1/4" DID 118 ROLLEN	O-RING CHAIN 5/8X1/4" DID 118 ROLLS	1
23	500.10.065.101	O-RING KETTE 5/8X1/4" PER METER	O-RING CHAIN 5/8X1/4" PER METER	X
24	500.10.066.100	KETTENSCHLOSS 5/8X1/4" O-RING	MASTER LINK 5/8X1/4" O-RING	1
25	583.10.050.044/30	KETTENRADTRÄGER KPL. SCHWARZ	SPROCKET SUPPORT CPL. BLACK	1
26	546.10.417.300	BÜCHSE F.KETTENRADTRÄG. L=25MM	BUSH. F.SPROCKETSUPPORT L=25MM	1
27	546.10.459.000	DÄMPFERGUMMI '91	DAMPING RUBBER '91	6
28	0625 032057	RILLENKUGELLAGER 3205.B.2RSR	GROOVED BALL BEAR. 3205.B.2RSR	1
29	546.10.018.000	NILOSRING 3205 AV	SEAL WASHER 3205 AV	1
30	520.10.073.000	FELGENBAND 18"-19"	RIM BAND 18"-19"	1
31	540.10.075.000	SCHLAUCH 4.00/4.50/120/130-18"	HOSE 4.00/4.50/120/130-18"	1
32	582.10.074.000	REIFEN 140/80-18" 70R ENDURO 3	TYRE 140/80-18" 70R ENDURO 3	1
38	550.03.135.000	BLINDSTOPFEN FÜR FELGE	PLUG FOR RIM	X
39	502.10.086.000	ABDECKKAPPE SFL16	COVERING CAP SFL16	2
40	502.10.085.044	STECKACHSE HINTEN KPL.L=264MM	WHEEL SPINDLE REAR CPL.L=264MM	1
41	565.10.084.100	KETTENSPANNER MIT BOHRUNG '95 GESCHMIEDET	CHAIN TENSIONER '95 FORGED	1
42	502.03.030.090	SK.SCHRAUBE M8X40 A2 SW=10	HH SCREW M8X40 A2 WS=10	2
43	0934 080003	SK.MUTTER DIN0934-M 8	HEXAGON NUT DIN0934-M 8	2
44	503.10.099.000	SK-MUTTER M20X1,5 '98	HEXAGON NUT M20X1,5 '98	1

* = NEUTEIL / NEW PART X = NACH BEDARF / AS REQUIRED

FIG	TEILNR/PARTNR	BEZEICHNUNG	DESCRIPTION	QTY
1	502.13.301.644	BREMSZANGE KPL. HINTEN LINKS	BRAKE CALIPER CPL. REAR L/S	1
2	546.13.318.200	REPARATUR SATZ DICHRINGE 34MM	REPAIR KIT SEALING RINGS 34MM	1
3	546.13.310.200	BOLZENSATZ	BOLT SET	1
4	546.13.309.200	GARN. BREMSKLÖTZE FERODO ID450	BRAKE PAD SET FERODO ID450	1
5	546.13.305.200	BREMSKOLBEN 34MM	BRAKE PISTON 34MM	1
6	545.13.214.000	ENTLÜFTUNGSSCHRAUBE M10X1	BLEEDER SCREW M10X1	1
7	546.13.218.000	MANSCHETTENSATZ	CUP SET SHORT	1
10	583.13.070.000	BREMSSCHLAUCH HINTEN 790MM '97	BRAKE HOSE REAR 790MM '97	1
11	502.13.025.000	HOHLSCHRAUBE M10X1X19	HOLLOW SCREW M10X1X19	1
12	420.13.226.000	CU-DICHTRING DIN7603-10X16X1	CU-SEAL RING DIN7603-10X16X1	1
13	420.13.026.000	CU-DICHTRING DIN7603-10X16X1,5	CU-SEAL RING DIN7603-10X16X1,5	1

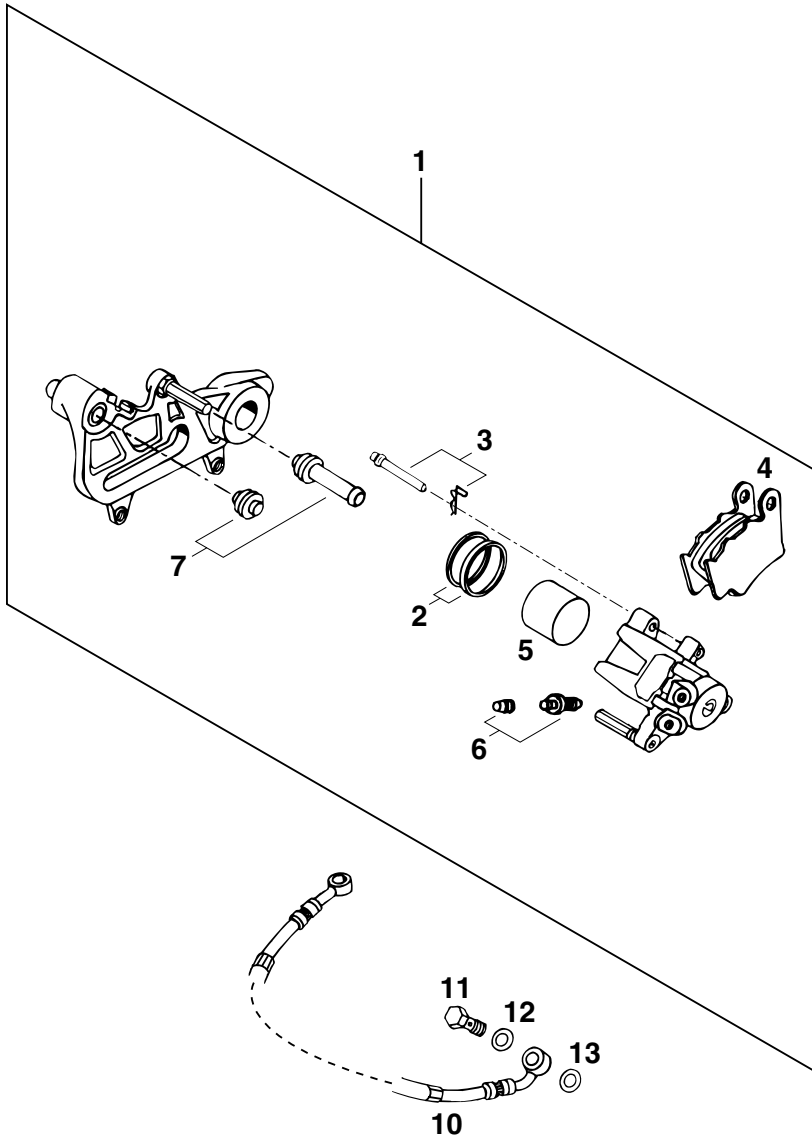
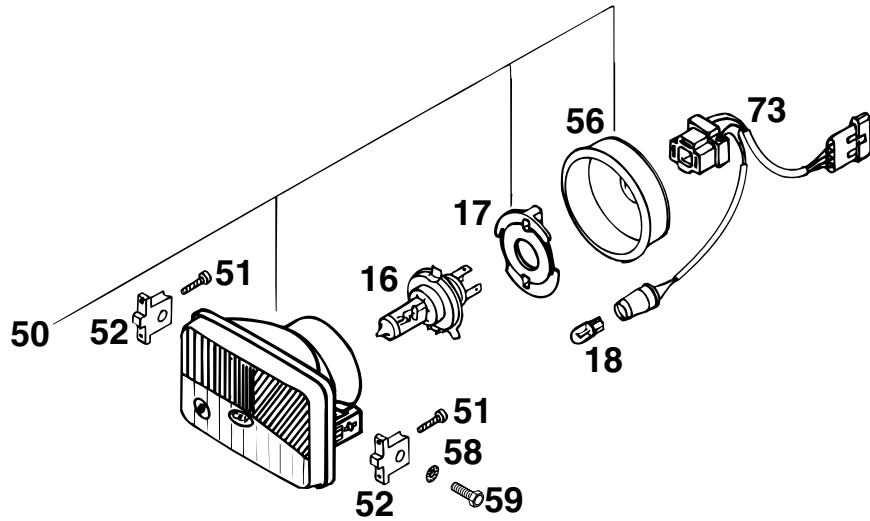

FIG	TEILNR/PARTNR	BEZEICHNUNG	DESCRIPTION	QTY
16	571.11.038.000	LAMPE H4 12V 60/55W (P43T)	BULB H4 12V 60/55W (P43T)	1
17	490.11.436.000	LAMPENHALTER	BULB HOLDER	1
18	490.11.435.000	LAMPE 12V 5W (W2,1X9,5D)	BULB 12V 5W (W2,1X9,5D)	1
50	502.11.510.000	SCHEINWERFER KPL. CEV 394 '93	HEADLIGHT CPL. CEV 394 '93	1
51	0981 350163	LI.BLECHSCHR. DIN7981- 3,5X16	SHEET MET.SCR.DIN7981- 3,5X16	4
52	584.14.010.000	SCHEINWERFERHALTERUNG '98	HEAD LIGHT SUPPORT '98	2
56	502.11.537.000	GUMMIKAPPE	RUBBER CAP	1
58	0797 060003	ZAHNSCHEIBE DIN6797-J 6,4	TOOTH LOCK WASH. DIN6797-A 6,4	2
59	0933 060203	SK.SCHRAUBE DIN0933-M 6X20	HH SCREW DIN0933-M 6X20	2
73	502.11.510.010	KABEL FÜR SCHEINWERFER '93	CABLE FOR HEADLIGHT '93	1



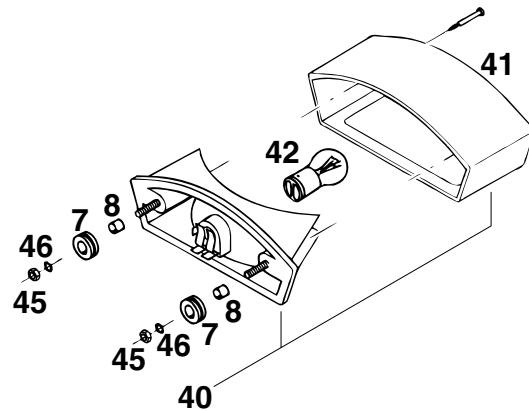
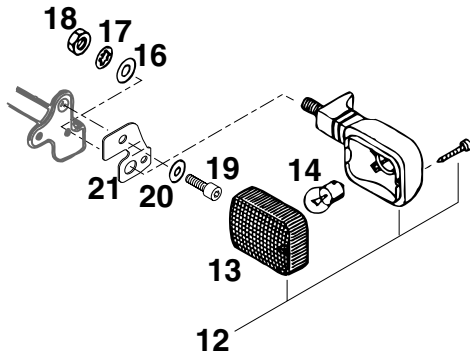

FIG	TEILNR/PARTNR	BEZEICHNUNG	DESCRIPTION	QTY
7	310.08.060.000	KABELTÜLLE D=8MM OFFEN	RUBBER SLEEVE D=8MM OPEN	2
8	580.11.039.000	DISTANZBÜCHSE 6,5 X 8 X 7	SPACER BUSHING 6,5 X 8 X 7	2
12	583.11.012.000	BLINKER VO.LI./HI.RE. '93	FLASHER FRONT L/S / REAR R/S	2
—	583.11.112.000	BLINKER HI.LI./VO.RE. '93	FLASHER REAR L/S / FRONT R/S	2
13	583.11.013.000	BLINKERGLAS LINKS UND RECHTS	FLASHER LENS L/S AND R/S	4
14	441.11.015.100	LAMPE 12V 10W (BA15S)	BULB 12V 10W (BA15S)	4
16	0125 100003	UNTERLEGSCHIEBE DIN0125-A10,5	WASHER DIN0125-A10,5	4
17	0797 100003	ZAHNSCHIEBE DIN6797-J10,5 ZI	LOCK WASHER DIN6797-J10,5 ZI	4
18	0934 102003	SK.MUTTER DIN0934-M10X1,25	HEXAGON NUT DIN0934-M10X1,25	4
19	0912 060163	ISK.SCHRAUBE DIN0912-M 6X16	AH SCREW DIN0912-M 6X16	2
20	0021 060003	SCHIEBE DIN9021-A 6,4	WASHER DIN9021-A 6,4	2
21	583.14.033.000	BLINKERHALTERUNG LI. GEBOGEN	FLASHER BRACKET L/S BENT	1
—	583.14.034.000	BLINKERHALTERUNG RE. GEBOGEN	FLASHER BRACKET R/S BENT	1
40	583.11.040.000	RÜCKLICHT KPL. CEV 358 '93	REAR LIGHT CPL. CEV 358 '93	1
41	583.11.041.000	LEUCHTHAUBE '93	LENS '93	1
42	570.11.045.000	LAMPE 12V 21/5W (BAY15D)	BULB 12V 21/5W (BAY15D)	1
45	0985 060003	SS.MUTTER DIN0985-M 6	SELF LOCK. NUT DIN0985-M 6	2
46	0021 060003	SCHIEBE DIN9021-A 6,4	WASHER DIN9021-A 6,4	2

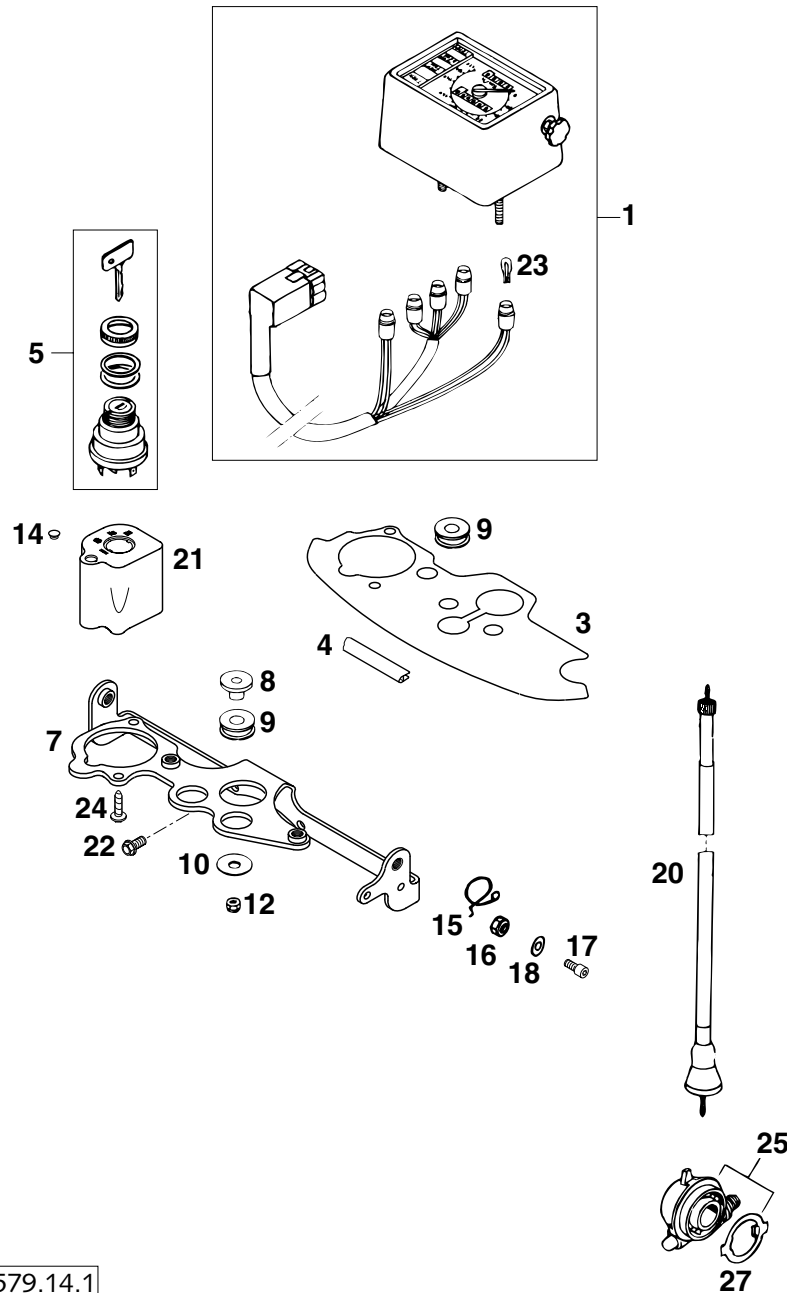

FIG	TEILNR/PARTNR	BEZEICHNUNG	DESCRIPTION	QTY
1	511.14.065.000	TACHOANLAGE NIPPON SEIKI KMH	SPEEDOMETER NIPPON SEIKI KMH	1
3	511.11.084.100	ABDECKUNG FÜR KONSOLE '97	COVER FOR CONSOLE '97	1
4	583.12.085.100	DICHTUNGSPROFIL F. ABDECKUNG	EDGE PROTECTOR FOR COVER	0,3
5	446.11.466.000	ZÜNDSCHLOSS 7-P CEV	IGNITION LOCK 7-P CEV	1
7	584.11.003.000	MASKENHALTERUNG '97	MASK BRACKET '97	1
8	546.35.036.000	BÜCHSE	BUSHING	2
9	410.01.052.000	KABELTÜLLE D=12MM	RUBBER SLEEVE D=12MM	3
10	0021 060003	SCHEIBE DIN9021-A 6,4	WASHER DIN9021-A 6,4	2
12	0985 060003	SS.MUTTER DIN0985-M 6	SELF LOCK. NUT DIN0985-M 6	2
14	361.11.021.000	VERSCHLUSSPFROPFEN	PLUG	1
15	580.11.008.000	FÜHRUNG FÜR BREMSSCHLAUCH	GUIDE FOR BRAKE HOSE	1
16	0985 050003	SS.MUTTER DIN0985-M 5	SELF LOCKING NUT DIN0985-M 5	1
17	0912 050123	ISK.SCHRAUBE DIN0912-M 5X12	AH SCREW DIN0912-M 5X12	1
18	0125 050003	UNTERLEGSCHIEBE DIN0125-A 5,0	WASHER DIN0125-A 5,0	1
20	584.14.055.100	TACHOWELLE M12/M12 950MM '98	SPEEDOM. CABLE M12/M12 950MM'98	1
21	584.11.066.050	GEHÄUSE FÜR ZÜNDSCHLOSS '97	HOUSING FOR IGNITION LOCK '97	1
22	0015 060123	SK.BUNDSCHRAUBE M 6X12 SW=8	HH COLLAR SCREW M 6X12 WS=8	2
23	491.11.425.000	LAMPE 12V 1,2W (W2X4,6D)	BULB 12V 1,2W (W2X4,6D)	X
24	0016 060203	PLASTITE SCHRAUBE Z 6,0X20	SPECIAL SCREW Z 6,0X20	2
25	581.11.052.100	TACHOANTRIEB 748217 (3,0)	SPEEDOMETER DRIVE 748217 (3,0)	1
27	581.11.053.100	MITNEHMER FÜR TACHOANTRIEB '92	DRIVING DOG F.SPEEDOM.DRIVE'92	1

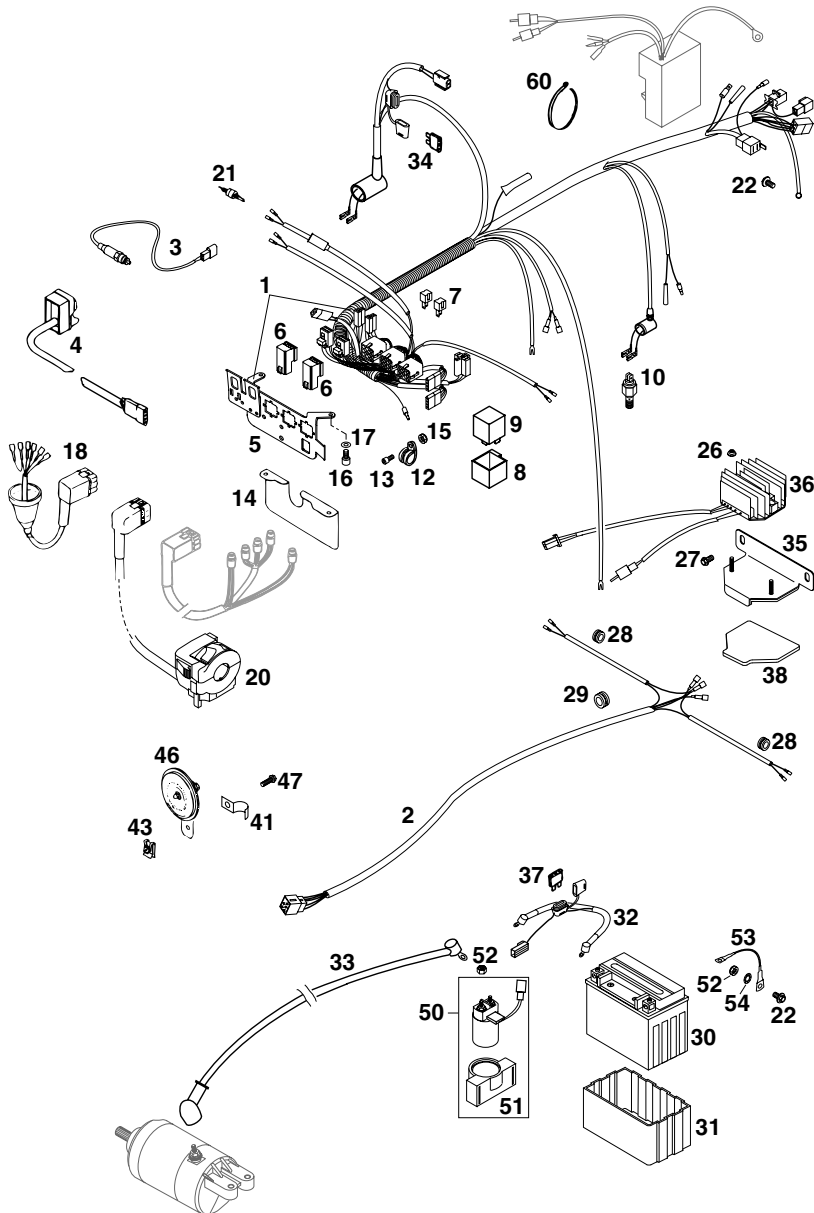

FIG	TEILNR/PARTNR	BEZEICHNUNG	DESCRIPTION	QTY
1	584.11.175.000	HAUPTKABELSTRANG LC4-E KPL.'97	WIRING HARNESS LC4-E CPL. '97	1
2	584.11.176.000	KABELSTRANG HI. LC4-E/DUKE '97	WIRING HAR. REAR LC4-E/DUKE'97	1
3	584.11.049.000	KUPPLUNGSSCHALTER '96	CLUTCH SWITCH '96	1
4	584.11.074.000	START NOT-AUS SCHALTER	START-STOP SWITCH	1
5	584.11.083.000	STECKERBORD KPL. E-START '97	BRACKET KPL. E-START '97	1
6	584.11.057.000	STARTERHILFSRELAIS '96	STARTER RELAY '96	2
7	584.11.096.100	DIODE FÜR E-START S3H-15 '97	DIODE FOR E-START S3H-15 '97	2
8	545.11.046.000	BLINKGEBERHALTERUNG	FLASHER LIGHT BRACKET	1
9	446.11.207.100	BLINKGEBER HELLA BRK '96	FLASHER UNIT HELLA BRK '96	1
10	503.11.051.000	BREMSLICHTSCHALTER HINTEN '97	REAR BRAKE LIGHT SWITCH '97	1
12	490.07.439.000	SCHELLE RSGU 15/12	CLAMP RSGU 15/12	1
13	0912 050123	ISK.SCHRAUBE DIN0912-M 5X12	AH SCREW DIN0912-M 5X12	1
14	583.11.083.051	ABDECKUNG STECKERBORD '93	COVER CONNECTOR SUPPORT '93	1
15	0985 050003	SS.MUTTER DIN0985-M 5	SELF LOCKING NUT DIN0985-M 5	1
16	0912 060123	ISK.SCHRAUBE DIN0912-M 6X12	AH SCREW DIN0912-M 6X12	2
17	0125 060003	UNTERLEGSCHIEBE DIN0125-A 6,4	WASHER DIN0125-A 6,4	2
18	583.11.077.000	KABELSTRANG-ZÜNDSCHLOSS '93	WIRING HARNESS-IGNITION LOCK	1
20	583.11.570.100	LICHTSCHALTER KPL. CEV '97	LIGHT SWITCH CPL. CEV '97	1
21	510.11.050.000	BREMSLICHTSCHALTER VORNE	FRONT BRAKE LIGHT SWITCH	1
22	0014 060103	SK.BUNDSCHRAUBE M 6X10 SW=8	HH COLLAR SCREW M 6X10 WS=8	2
26	565.09.064.000	STOVER-FLANSCHMUTTER M6	SELF LOCKING NUT M6	2
27	0015 060103	SK.BUNDSCHRAUBE M 6X10 SW=8	HH COLLAR SCREW M 6X10 WS=8	2
28	575.11.027.000	KABELTÜLLE D=6MM OFFEN	RUBBER SLEEVE D=6MM OPEN	2
29	310.08.060.000	KABELTÜLLE D=8MM OFFEN	RUBBER SLEEVE D=8MM OPEN	1
30	584.11.053.000	BATTERIE 12V 8AH '96	BATTERY 12V 8AH '96	1
31	584.11.053.050	BATTERIEHÜLLE AUS GUMMI '96	BATTERY COVER (RUBBER) '96	1
32	584.11.059.350	BATTERIEKABEL 190MM 15A '98	BATTERY CABLE 190MM 15A '98	1
		BATTERIE - STARTRELAISE	BATTERY - STARTRELAY	
33	584.11.059.100	STARTERKABEL 700MM '97	STARTERCABLE 700 MM '97	1
		STARTERRELAISE-STARTERMOTOR	STARTERRELAY-STARTERENGINE	
34	580.11.109.005	STECKSICHERUNG 5 A	FUSE 5 A	1
35	584.11.055.100	BATTERIEHALTEBÜ. LC4-E/DUKE'97	BATTERY BRACKET LC4-E/DUKE'97	1
36	584.11.034.100	REGLER-GLEICHRICHTER 12V '97	VOLT.REGULATOR-RECTIFIER 12V	1
37	580.11.109.015	STECKSICHERUNG 15 A	FUSE 15 A	1
38	584.11.055.150	METAMOLL F. BATTERIEHALTEBÜGEL	METAMOLL FOR BATTERY BRACKET	1

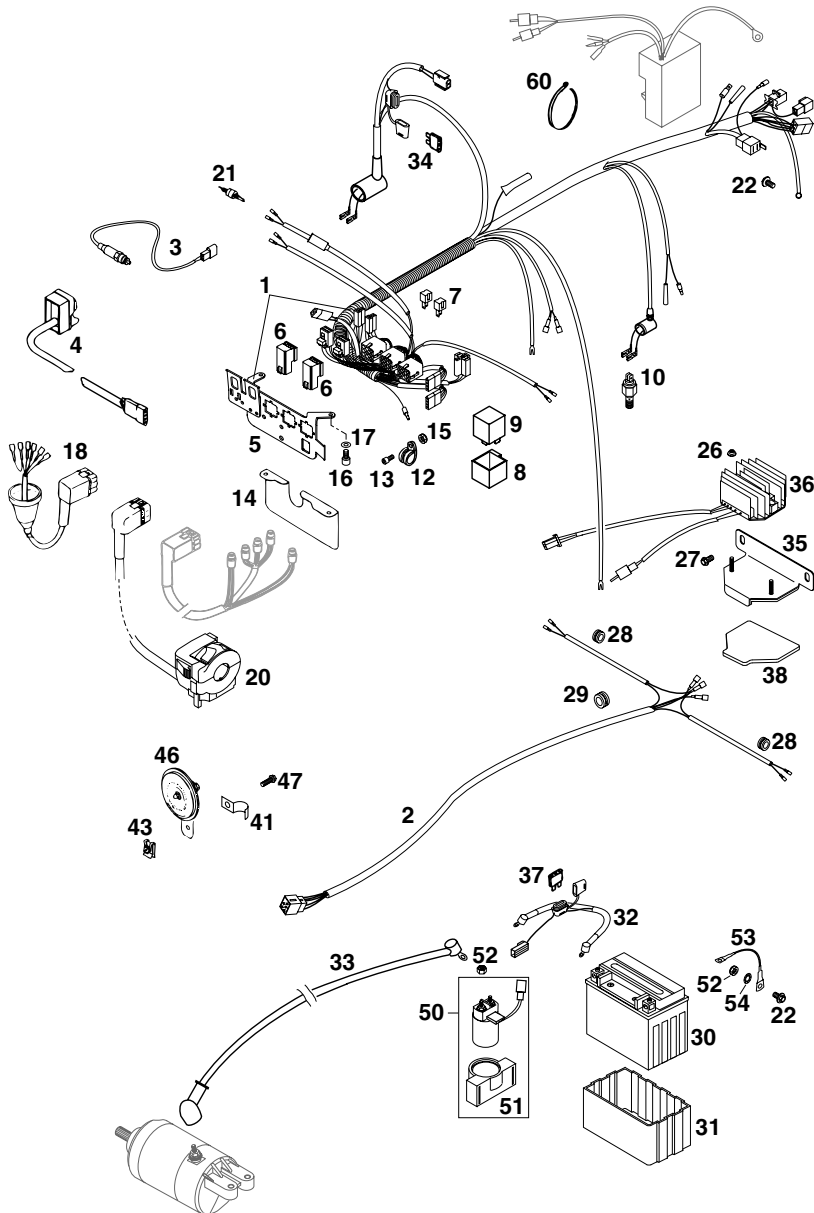

FIG	TEILNR/PARTNR	BEZEICHNUNG	DESCRIPTION	QTY
41	502.11.096.000	SHELLE FÜR KABELSTRANG	CLAMP FOR WIRING HARNESS	1
43	546.03.048.100	MEHRBEREICHSBLECHMUTTER M6	RANGE CHANGE METAL NUT M6	1
46	545.11.060.100	GLEICHSTROMHORN 12V NIKKO	DC HORN 12V NIKKO	1
47	0015 060163	SK.BUNDSCHRAUBE M 6X16 SW=8	HH COLLAR SCREW M 6X16 WS=8	1
50	584.11.058.000	STARTERRELAIS MIT HALTEGUMMI	STARTER RELAY WITH HOLD.RUBBER	1
51	584.11.058.050	HALTEGUMMI FÜR STARTERRELAIS	HOLD. RUBBER FOR STARTRELAY	1
52	0985 060003	SS.MUTTER DIN0985-M 6	SELF LOCK. NUT DIN0985-M 6	2
53	584.11.097.100	MASSEKABEL D=6MM L=140MM '97	GROUND CABLE D=6MM L=140MM '97	1
54	584.11.098.100	KONTAKTSCHIBE M6 VSV-K6	CONTACT WASHER M6 VSV-K6	1
60	440.11.076.305	KABELBAND 290MM	CABLE TIE 290MM	X
—	440.11.076.200	KABELBAND 200MM	CABLE TIE 200MM	X

FIG	TEILNR/PARTNR	BEZEICHNUNG	DESCRIPTION	QTY
15	583.12.011.000/30	GEPÄCKTRÄGER SCHWARZ (MATT)	BAGGAGE CARRIER BLACK	1
16	0991 060203	SENKSCHRAUBE DIN7991-M 6X20	FLAT HEAD SCREW DIN7991-M 6X20	2
17	400.06.006.000	FASSONSCHIEBE 6MM	WASHER 6MM	2
18	565.09.064.000	STOVER-FLANSCHMUTTER M6	SELF LOCKING NUT M6	2
20	0912 060303	ISK.SCHRAUBE DIN0912-M 6X30	AH SCREW DIN0912-M 6X30	2
21	502.32.050.001	STAHLSCHEIBE 6X17X3	STEEL WASHER 6X17X3	2

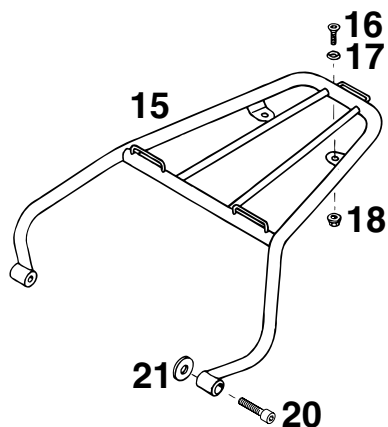
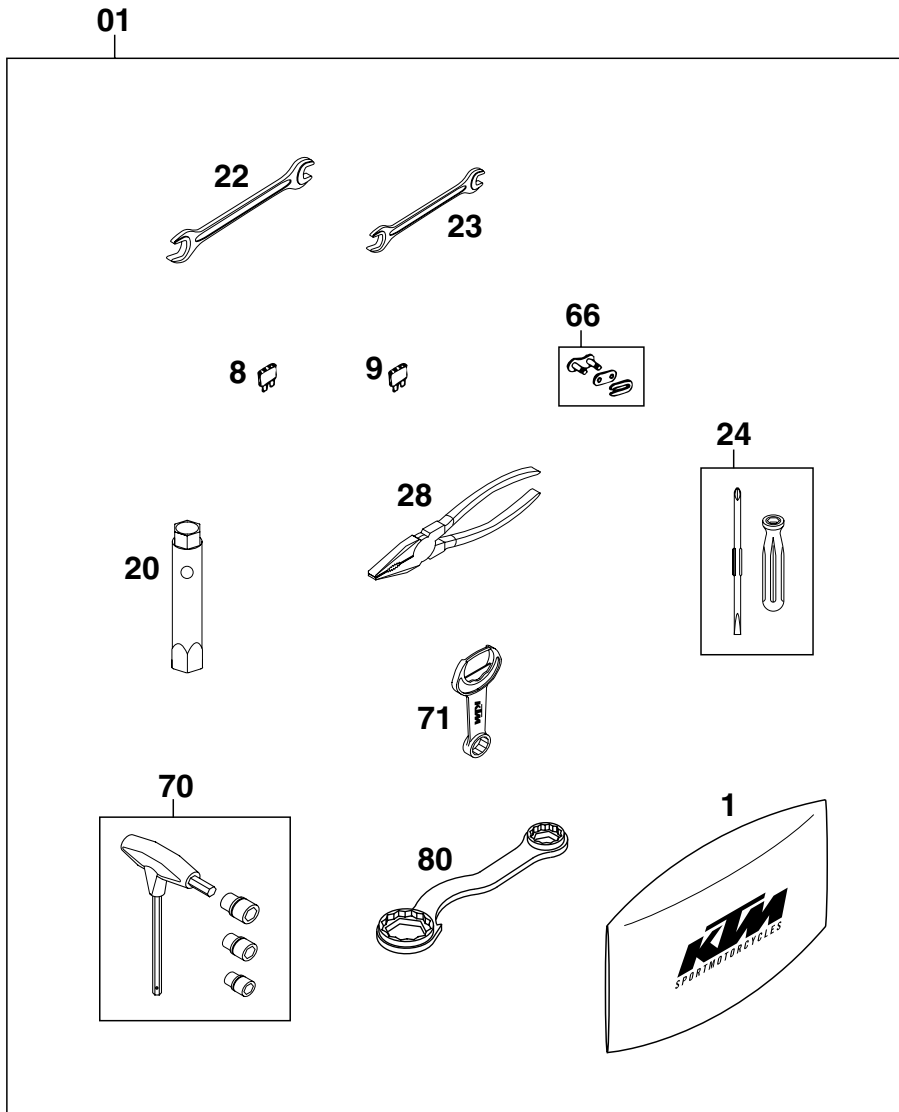

FIG	TEILNR/PARTNR	BEZEICHNUNG	DESCRIPTION	QTY
01*	579.29.099.000	BORDWERKZEUG SCHWARZ MIL. BRD	TOOL SET BLACK MIL. BRD	1
1	583.12.100.050	WERKZEUGTASCHE GROß SCHWARZ	TOOL BAG BIG BLACK	1
8	580.11.109.015	STECKSICHERUNG 15 A	FUSE 15 A	1
9	580.11.109.005	STECKSICHERUNG 5 A	FUSE 5 A	1
20	580.12.020.100	ZÜNDKERZENSCHLÜSSEL SW=16/18	SPARK PLUG WRENCH WS=16/18	1
22	510.12.023.100	GABELSCHLÜSSEL SW=10/13	WRENCH WS=10/13	1
23	510.12.023.000	GABELSCHLÜSSEL SW=8/10	WRENCH WS=8/10	1
24	530.12.024.100	SCHRAUBENZIEHER L=105MM	SCREW DRIVER L=105MM	1
28	530.12.028.000	KOMBIZANGE	GRIP	1
66	500.10.066.100	KETTENSCHLOSS 5/8X1/4" O-RING	MASTER LINK 5/8X1/4" O-RING	1
70	503.29.070.000	T-SCHLÜSSEL SW=6/8/10 '97	T-WRENCH WS=6/8/10 '97	1
71	503.29.071.000	SCHLÜSSEL SW=13/17	WRENCH WS=13/17	1
80	503.29.080.000	KOMBISCHLÜSSEL SW=17/21/27/32	WRENCH WS=17/21/27/32	1





*K T M - S P O R T M O T O R C Y C L E A G
A-5230 Mattighofen • Postfach 91 • Austria
Internet: <http://www.ktm.co.at>
FN 102019 d - Landesgericht Ried im Innkreis*

Gedruckt auf chlorfrei gebleichtem, umweltfreundlichen Papier. - aumayer-druck-mattighofen